

The Future of Plagiarism

Professor Pinker has not completely exhausted the dirty tricks that are possible with print. As we will see, he missed a few. I would have to guess that the internet and the computer will provide the next unexplored territory for creative plagiarism. Creative genius may be able to forge false dates on existing publications, or create bogus publications. The creative plagiarist might re-publish a published document, placing someone else's name on it, and accuse the victim of plagiarism. A creative forger might be able to generate a false publication with some earlier hero's name on it: I was once informed that the particulate principle can be found among the works of Ferdinand de Saussure. I couldn't find any such reference, but a determined forger might create one. Electronic media are modifiable by their nature, so the world of publication becomes a hall of mirrors, where nothing is for sure. A plagiarist might go back and change a few words in an earlier publication, and who would know? It is only a matter of time before the internet comes into its own as a medium for creative theft and refutation.

What to do? What to do?

All institutions of research, science or learning must take positive steps to make the victim of plagiarism whole, as far as that is possible, even extending to the victim's heirs a hundred years after the original author's death. Firing the plagiarist does nothing to restore the victim, and only provides the institution an excuse for claiming that they have cast out the evil, when all they have done is shed responsibility. Firing is an easy escape for the institution. Faculty appointments are collective. All faculty share responsibility for any appointment. If you can bask in the plagiarist's wonderfulness before plagiarism is discovered, there is a responsibility to restore the victim's life after plagiarism is discovered, to the extent that that is possible.

To the absolute minimum, the plagiarist must be required to withdraw the stolen material. And the plagiarist must publish an apology and reference to the original – preferably on the front page of the Sunday New York Times. Where possible, the plagiarist must release the offending material to the victim, or into the public domain, and must arrange for the original material to be re-published with a clear reference to the original. If the plagiarist has made any considerable amount of money off the copied material –and this extends to increased profits from later books and fees and honoraria resulting from the plagiarist's enhanced reputation, half belongs to the victim. It is impossible to restore a life and a lifetime, but at least the victim might leave something to his/her children, and the future might know the real originator of the valued material, so carefully selected by the plagiarist.

About the Author

I can tell you, in a way that Professor Pinker can't, how the critical role of discreteness was discovered. In 1980, I promised myself that I would "solve the mystery of language", whatever that meant to me at the time. I had been studying honey bees for six years, doing lesion experiments on their brain, trying to learn

something about lateralization. When I realized that lateralization isn't language, I sensed, for the second time, that I must ration the years of my life as a resource in finding a solution: When I was four, I saw the word "pasteurized" on the caps of the milk bottles, and asked my grown-ups what that meant. I remember the spot next to the fence in my parents' back yard where I gave myself eighty years to do something "worthy of the great Pasteur" as I understood it then. I know better now. I remember being awed and terrified the first time I cut open the cocoon of a Cecropia moth and saw the pupa. It looked to me like something mythical and mystical, endowed with unknowable powers, like an Egyptian mummy in its sarcophagus.

In spite of abstract theories, I have always thought of myself as a laboratory biologist. I guess I still do. Here is a photo of me, probably around age twelve, holding a hydraulic micro-manipulator that I made, for removing the nuclei of paramecia, if I remember right. The paramecia were held in a glass capillary, lined up like railroad cars on a siding.

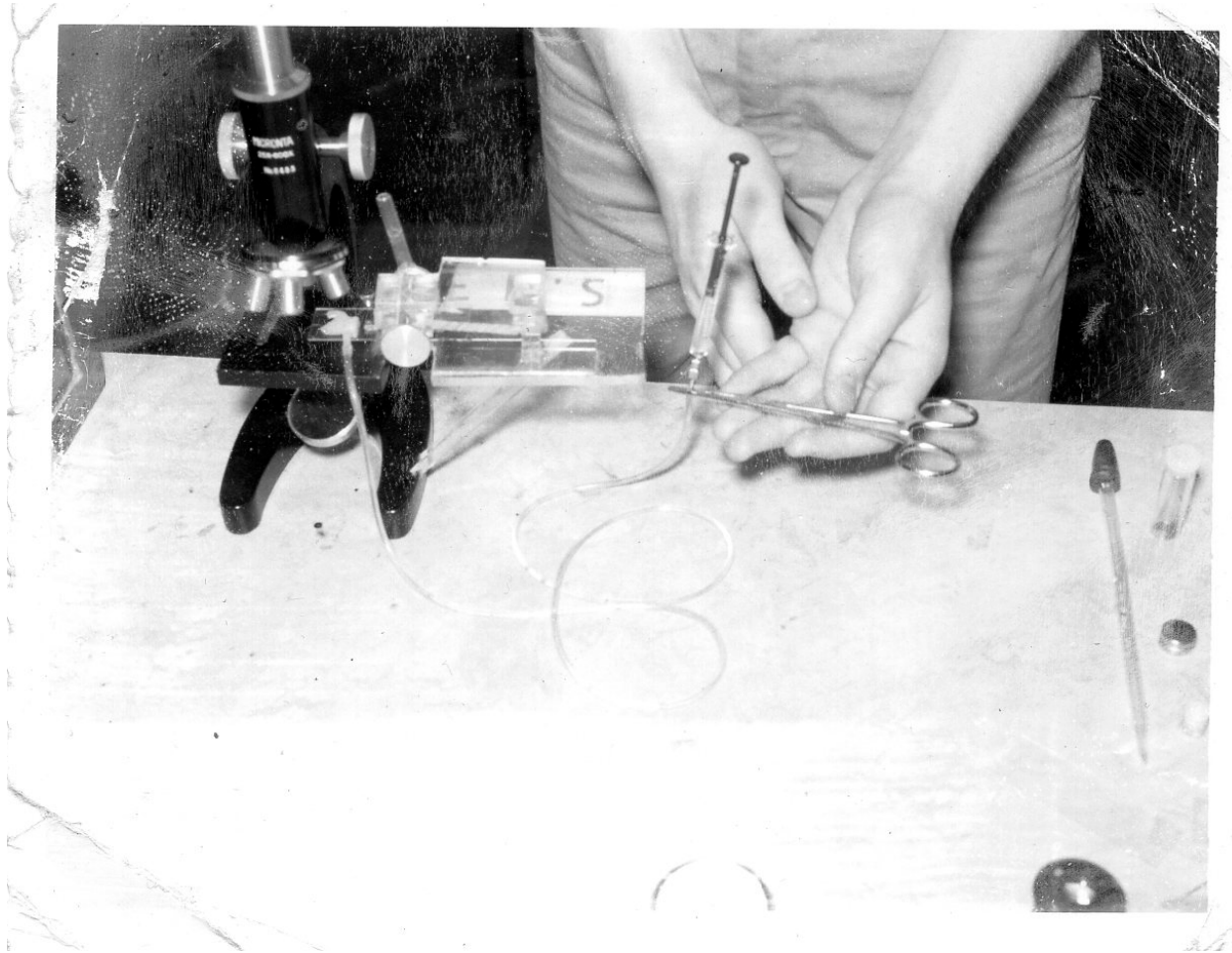

I have always been interested in language, and when I got to College, wanted to put my two interests together. I asked Vincent Dethier, author of *To Know a Fly* [Holden Day 1962] and at that time professor at my university, which major I should take – Linguistics or Biology. He told me, “You can learn biology out of a book, but not linguistics. Take Linguistics”. He was right. I did.

I was the first person in Philadelphia to own a copy of Eric H. Lenneberg’s *Biological Foundations of Language* (Wiley 1967). I called the publisher in New York, and they told me the name of the bookstore, and the day, when the first delivery would arrive. I went there and met the truck at the loading dock. The driver was sympathetic. He found the right carton for me, and opened it, and pulled out a copy and handed it to me. I walked into the store and bought it. For a couple of months, I was a minor celebrity for my unique possession. In spite of popular enthusiasm, I found the book strangely vacant.

I took one or two courses with Zellig Harris, Chomsky’s mentor; and the other graduate students asked me why I didn’t study syntax. I said that I would, but I had to come to it in my own way. That was around 1969. It was thirty years before I came to grips with syntax, and I came to it in my own way. In graduate school, when my ideas were not yet formed, I took phonetics, the most biological of the language sciences.

One day, after I had become a graduate student, I was standing at the bottom of the stairs in the Annenberg School, when Michael Studdert-Kennedy appeared at the top. “Stay right there” he ordered. He disappeared for a minute, and came back and handed me a reprint of Liberman, Cooper, Shankweiler and Studdert-Kennedy 1967, Perception of the Speech Code, *Psychological Review* 74(6)431-461. The main point (pages 435, 437) was that the cue to the perception of stop-consonants, b, d, g, the most deeply encoded of the speech sounds, is a band of moving sound-frequency during the production of speech. While the frequency of the band points back toward a characteristic target frequency for each consonant, b, d, or g, the target frequency is never realized in the actual acoustic signal.

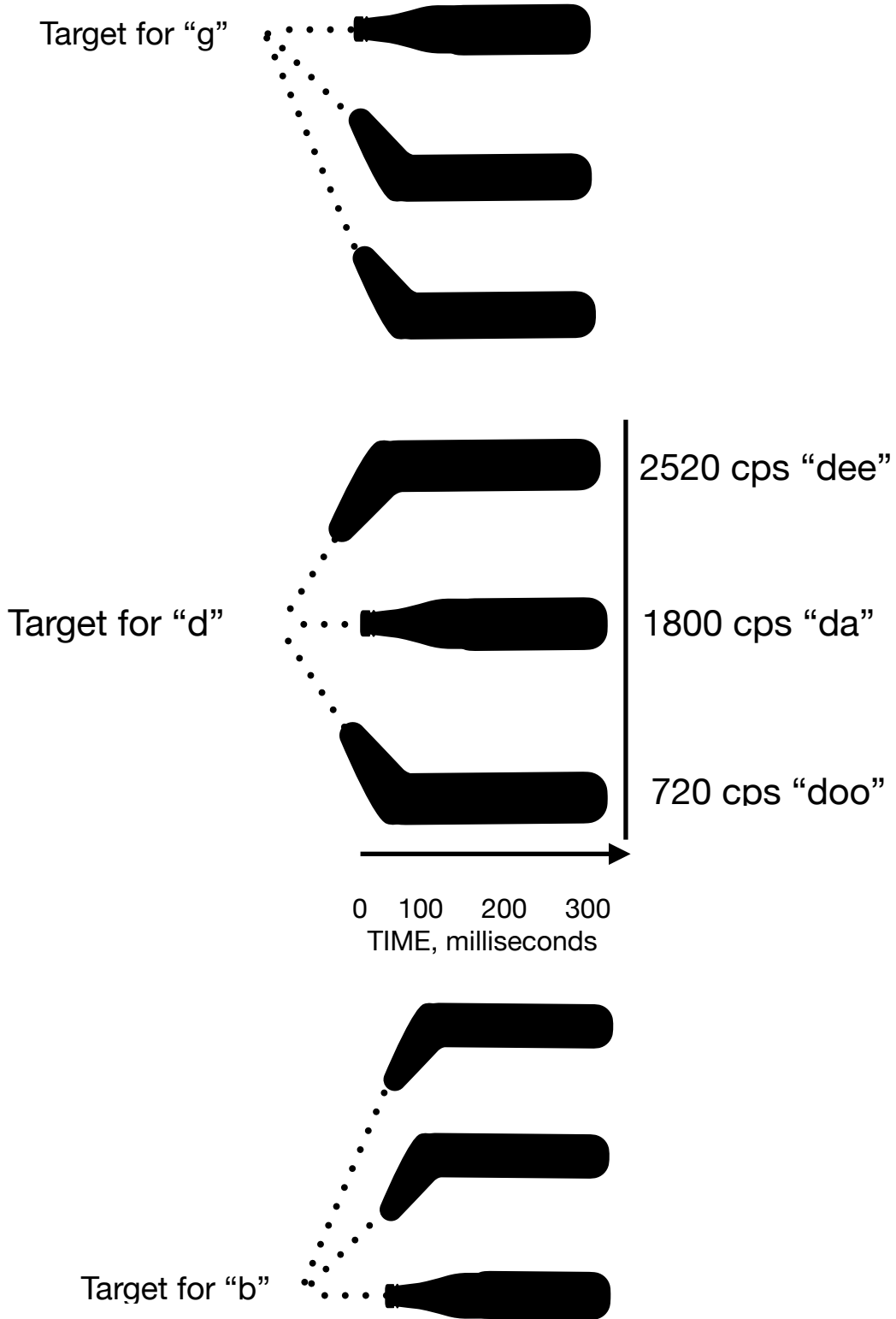

I saw immediately that the target frequency is realized, but you don't hear it because the vocal tract is closed at the point of articulation, lips for "b", tongue-tip for "d", or back-of-the-tongue for "g". The sound doesn't begin to come out until after the vocal tract has moved away from the target frequency –and I built a working model of the vocal tract, my talking machine, to prove it. First, here is how the sound frequencies were discovered, and the stories that always go with the science.

The Pattern Playback

My look at the Pattern Playback and its heart, the Tone Wheel, is personal and intimate, and brings back more than I want to remember. The Pattern Playback produced a direct synthesis of sounds in a two-dimensional spectrum display of frequency (on the vertical axis) versus time (on the horizontal axis). So, by painting a sound pattern onto a moving celluloid belt, an experimenter could convert the geometric pattern directly into a sound pattern. Under the scientific guidance of Alvin Liberman, and the engineering guidance of Franklin S. Cooper, the Pattern Playback showed the precise sound patterns that listeners interpret as speech. The results caused a revolution. To make a long story short, the Pattern Playback showed that the sound-signal of speech isn't a cipher like the Morse Code, with a one-to-one correspondence between the letters and the dots-and-dashes. The speech-signal is a true code, in other words, there is no one-to-one correspondence between the acoustic signal and the perceived sounds that we represent as letters of the alphabet. You can't take a tape recording of speech and cut it up and re-arrange the letters to get a different message.

This is a big deal. The phoneme, the discrete perceived speech-sound, was recognized during World War II; and the original hope was that it would lead to the construction of a translating machine. A fighter pilot could dial in on a foreign language with an attachment to his cockpit radio, and listen in on enemy radio transmissions. The earliest plans for the sound spectrograph were classified. The Pattern Playback showed that things weren't so simple. When I was a graduate student, my adviser told me that he had made the tone wheel by pouring India ink over a plate-glass wheel, and carving out sinusoidal clear spaces with a razor blade. He told me that he was working in an attic garret under conditions so hot that his health was threatened. I asked him how he traced the curves. "With a pencil" he told me, but I never found out how he matched up the ends of the curves coming around full circle.

The Talking Machine

I built my working model of the human vocal tract, and by inserting and removing an artificial palate, found that the shape of the vocal tract is critical to its ability to produce the sounds of speech. It was originally intended to show that the speech gestures are an invariant correlate to the perceived speech-sounds. I built most of it at home, but back at graduate school, the Chairman of the Art Department gave me the key to the Department workshop, "Because I want my artists too see this kind of detailed work", he said. My adviser wouldn't look at it, because a colleague of his was saying that the shape of the vocal tract is vital to its ability to produce the

sounds of speech, although his paper was not yet published. That study was a matter of natural history observations, with no experimental demonstration, while mine was a controlled experiment –everything the same except the presence or absence of the artificial palate.

One of the other graduate students, now forgotten, warned me that my adviser is known as “the iron hand in the velvet glove”. I thought it meant that he would really make me learn everything. In the end, I learned more than I wanted to know. Once, my adviser even placed his hand over his eyes when I brought the talking machine into his office, so he could claim, in technical truth, that he never saw it. I built a cam to show that there is a constant event corresponding to the phonemes, but my adviser told me in an uncharacteristic and, I suppose, well-rehearsed “If you ever want to receive a Ph.D. from any university in these United States, you will drop this project”.

The talking machine was an artificial vocal tract made of plasticized vinyl squidgy toys, that I melted down and cast in a mold made of copper sheet. I couldn't get instructions for casting the plastic, so I called the company. A factory-hand on the loading-dock answered the phone: “They won't let me see how they make it, but they use heat.” That was all I needed. I built the mold from copper sheet cut to shape and soldered together. I realized that a round vocal tube wouldn't close because it would retain little “grins” at the corners, so I made a tube with lens-shaped cross-section. This called for some fancy soldering, and holding the sheets of metal together with copper wires. I used high-vacuum silicone grease for a parting agent in the mold. The artificial muscles turned on nylon bushings, threaded onto a bronze rod. I couldn't get a drill bit the exact size to fit the bronze rod, but found that if I used the next smaller drill size, and heated the drill bit by friction with the nylon, I could get bushings that fit the bronze rod perfectly, and turned without friction or wobble. To accommodate the inflow of air during the production of stops b, d and g, I built a vinyl bellows, with membranes and edges cut around the edge of copper templates, and glued together with special cement. The larynx was a cylinder cast in silicone rubber, with a hole through the center, and a silicone-rubber block half-covering the opening, and a sheet of the squidgy vinyl plastic stretched across the half-circular opening, and held in place with copper wires. The top of the vocal tube radiated too much sound, so I built an artificial head with grey plasticene clay given to me by an artist friend. I still have the clay and the friend. I was really proud of the whole thing. The talking machine also showed that saliva is necessary for speech.

I included a drawing of the mold for casting the vocal tube on page 72 of my 1973 book *The Sensuous Gadgeteer* (Philadelphia: Running Press). The drawing shows the right-angle seam that you need for making cylinders, and the beveled seam that you need for making lens-shaped tubes. Page 98 shows the system for suspending the vocal tube from brackets. And page 103 shows the jig for making identical brackets to hold the “muscles” for opening and closing the vocal tube. The drawing is from page 72 of the 1973 printing (page 74 of the 1976 printing).

I used the above method to solder seams in the mold I used for casting the tube in my working model of the human vocal tract. The tube had to be of lens-shaped cross section \diamond (not oval \circ) so that the mold needed to have sharp, soldered seams along the edges. The procedure will work for silver soldering seams in any sheet metal mold, tank, or other contrivance.

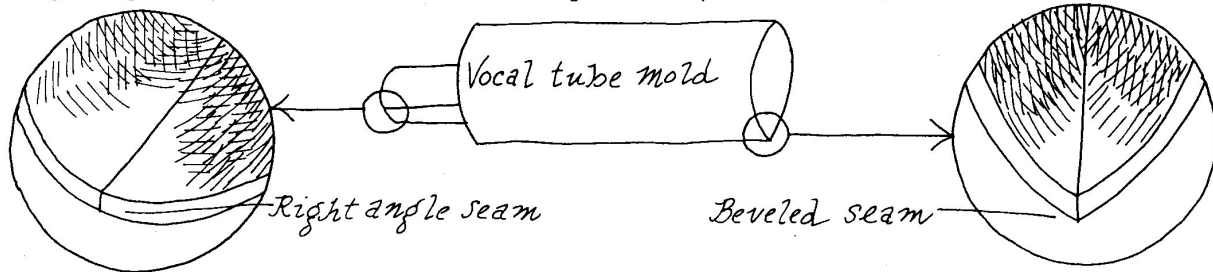

Shown below are two spectrograms made with my talking machine. The spectrograms show bands of sound frequency that the ear interprets as vowels, “ee”, “aa” and “oo”, the same as in the spectrograms shown above. Both spectrograms were made with an artificial Plasticene clay palate inserted in the vocal tube. One palate was sculpted in the profile of a gorilla palate, the other with the profile of a modern human palate, as shown in the Figure. The bands of sound frequencies, called “formants”, are clearer and more distinctly defined with the human palate than with the gorilla palate. This is the controlled, single-variable-factor experiment showing that the shape of the vocal tract is critical to its ability to produce the sounds of speech. The thin vertical lines in the spectrograms show the pops or bursts of noise produced by the vocal cords as they vibrate open and shut. As the bursts of noise enter the mouth cavity, some frequencies resonate and are amplified, while others are damped out. Speech-sounds are produced by varying the configuration of the tongue and lips as a way of varying the frequency of the sounds that are damped or amplified.



Molds for casting the lens-shaped vocal tube out of widgey vinyl plastic. The inner mold, at right, is smaller than the outer one. When the two forms are assembled for use, a copper circle is soldered to the small end of the outer mold, and the end of the inner mold is bolted to it. The melted plastic is then poured into the space between the inner and the outer molds. A layer of heavy silicone grease spread on the surfaces of the mold components acts as a release agent.



The talking machine today. At the right is the widdy vinyl vocal tube held in a curved copper roof, and covered with modeling clay to stop loss of sound. At left is the bronze rod with its nylon bushings, and plastic levers attached with brass straps. Each plastic lever has a brass wire arch at the end, which can press on the vocal tube, changing its shape and its acoustic profile. The clay box at the upper left of the clay housing contains the vinyl bellows that accommodates air for the voicing that precedes release of the stops "b", "d", and "g". It is during this voicing that the target frequency is realized.

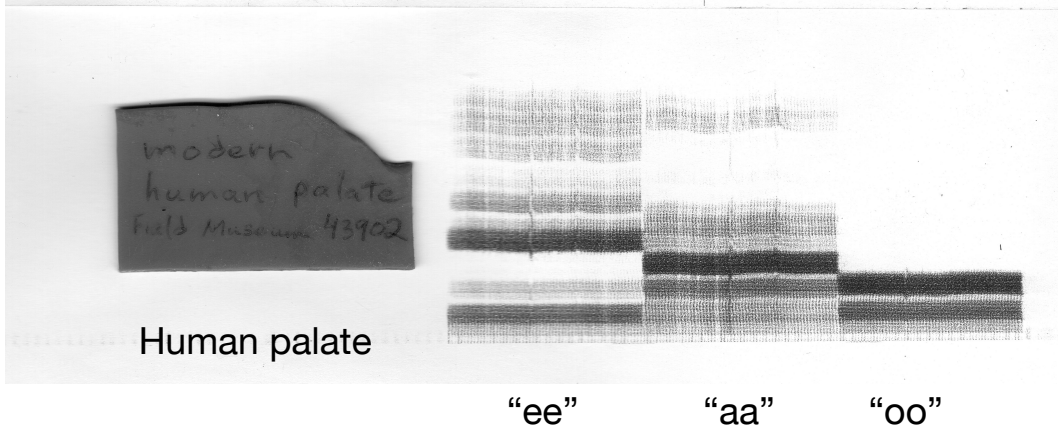
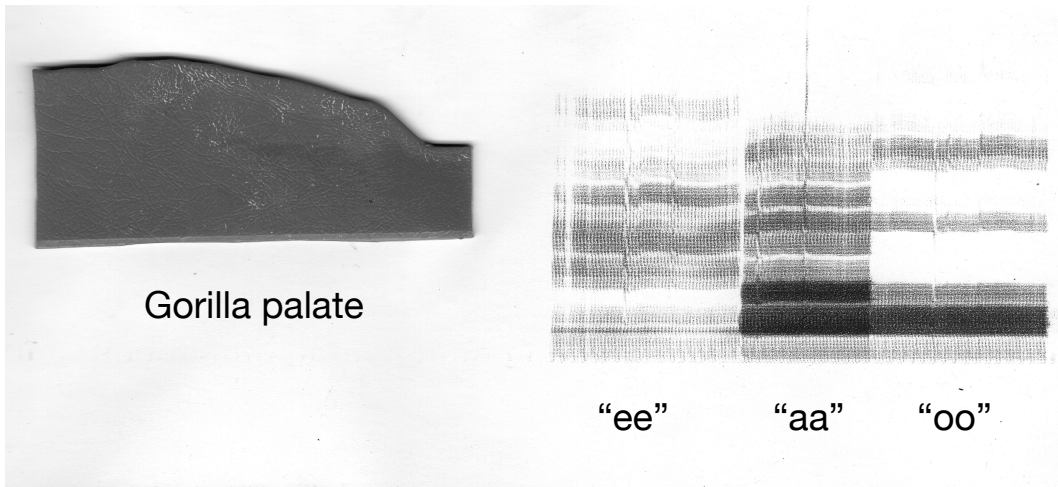

I didn't handle the situation well. I froze. I was terrified and bewildered, and never completed the experiments properly. I completely forgot about the unitary target frequency for the speech-sounds. I knew that the only path to my doctorate led through my adviser. I asked my Department Chairman for a different adviser, but he told me, "If I give you a different adviser, the new one will be seen as having scored some kind of victory over the old one, and I will have to live with the consequences long after you are gone." "How about a different school?" "For that you will need letters from us. And if the faculty know you are trying to escape, you will get bad letters. You won't get in, and the faculty won't want you here" [that's close enough]. I repaired the broken sound spectrograph machine, but didn't complete my experiments with proper spectrograms. In the end, my dissertation was on speaking rate, and I was so fed up with linguistics, and linguists, that I hoped never to see either again. Somehow, I knew that, sometime, my adviser would suggest that I could make a lifetime career out of speaking rate. After all, I was at the top of the game –as I would be later with skull measurements and comparative insect brain anatomy and serrated teeth. I could study speaking rate in the languages of the world, and be the go-to guy for speaking rate, in the way that some are for linguistic tone. I could travel the world, studying diverse languages in remote places, be sought after at meetings. And sure enough, when I ran into him at a conference, my former adviser suggested that I could make a career out of speaking rate. I took a postdoc fellowship in Neuropsychology at Stanford with Karl Pribram. I wanted something more basic.

Karl was a brain surgeon, and his lab concentrated on Karl's basic skill. They identified the function of different brain regions by teaching a monkey to do some task, like push a button when a symmetrical symbol appeared on a screen –then Karl would open up the monkey's head, remove part of the brain using a suction tube that we affectionately called the "Pribram sucker", and if the monkey couldn't perform the same task later, the removed brain region had something to do with the original task. There was histology, which I watch with great interest, and which I later used myself in studying honey bees.

Surgery Day was a kind of festival, where everyone turned out to watch. Karl was Odysseus at the helm, leading the lab into the brave unknown. There is an undeniable magic in seeing the living brain exposed for all to see, even if it is a monkey, not a person. But an old hand in the Lab warned me, "It's an illusion. You see the brain right there, and you get an impression of deep understanding, when in fact you understand nothing".

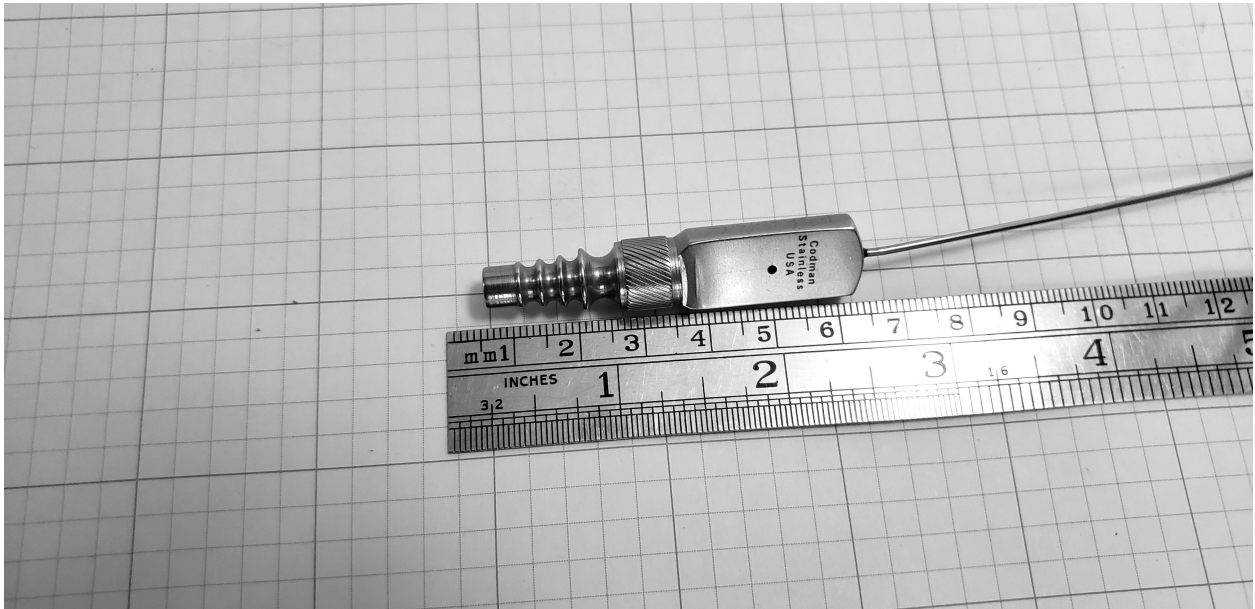

The Pribram suction device as I remember it. The ridged end, at left, was attached by a flexible hose to a vacuum bottle. An airway extends from the tip of the hollow steel tube, at right, through the suction device, to the vacuum bottle. A vent visible at the center of the grip allows air to pass directly into the vacuum bottle. When the vent is closed with a finger, the vacuum at the tip of the steel tube sucks white matter from the surface of the brain.

Nevertheless, I loved being in a real lab. When a baby gorilla appeared at the San Francisco Zoo, Karl sent me to visit her with Penny Patterson. I played with the baby gorilla on public exhibit at the Zoo, and built the first living-unit in a house-trailer for Koko the Gorilla. The idea was to minimize the risk of exposing Koko to human diseases by exposing her to as few people as possible –and I knew both linguistics and carpentry. I never fully joined Penny's team, but I remained a friend of the Koko project, and later even caught a rabbit for Koko to keep as a pet.

I also watched Jim Dewson's ape-language experiments as an interested visitor, and got a grasp of how they work. Jim had the hypothesis that aphasia was a matter of interference from the damaged side of the brain, so he taught his experimental apes to use one hand in preference to the other.

When Beatrice and Allen Gardner, the trainers of Washoe, came to Stanford for three days, Penny and I became their self-appointed hosts. When we walked with them down the long avenue to the train station, tiny Beatrice insisted on carrying her own huge briefcase.

In the end, I felt I had seen enough to have a fair sense of the state of the ape-language experiments, and the extent of their success, which was doubtful.

In 1974, I got an assistant professorship at a technical university in the Midwest. I taught linguistics, and kept trying to relate language to the brain. Back then, I still thought that lateralization must be a vital component of language, and while pouring seeds into the temporal cavities of ape skulls at The Field Museum, to measure their volume, I wondered whether asymmetry could be found in the skulls of fossil humans. The result was:

Abler, William L. 1976. Asymmetry in the skulls of fossil man: evidence of lateralized brain function? *Behavior and Evolution* 13(2-3):111-115.

At that time, the machine-tool manufacturers were offering very high-end measuring devices, with stainless styluses and ruby tips. I attended the Machine Tool Show and marveled at their versatility and accuracy, and size, but sensed that the secret of the human being didn't lie in skull measurements, so I let it go.

Next, still fascinated with lateralization, the asymmetry of brains, I wondered whether asymmetry had something to do with communication, and so began my romance with the honey bee. Anyone who wants to study bees has to become a beekeeper, so, after three days of agonizing over whether I could put up with the stings, I started reading, and ordered three pounds of workers and an Italian queen. The community of beekeepers was very cordial. I was happy to be back in lab science. The Psychology Department graciously gave me lab space where I did my histology. The Chemistry Department gave me lab space; and the biologists gave me rare and wonderful stains. The brains of insects are sculpted to fit the shape of the head, which in turn is evolved to suit the kind of life that the insect pursues. I knew that I could make a career out of the comparative brain anatomy of insects and spiders. But that, too, wasn't basic enough, so I let it go.

Here is a picture of one of my silver-stained honey-bee brains, shown in serial section. The eyes are located at the right and left ends of the sections, with the optic lobes medial to those, and the cerebrum at the center. The slide is 3 inches by one inch, and the brains are about three millimeters wide.

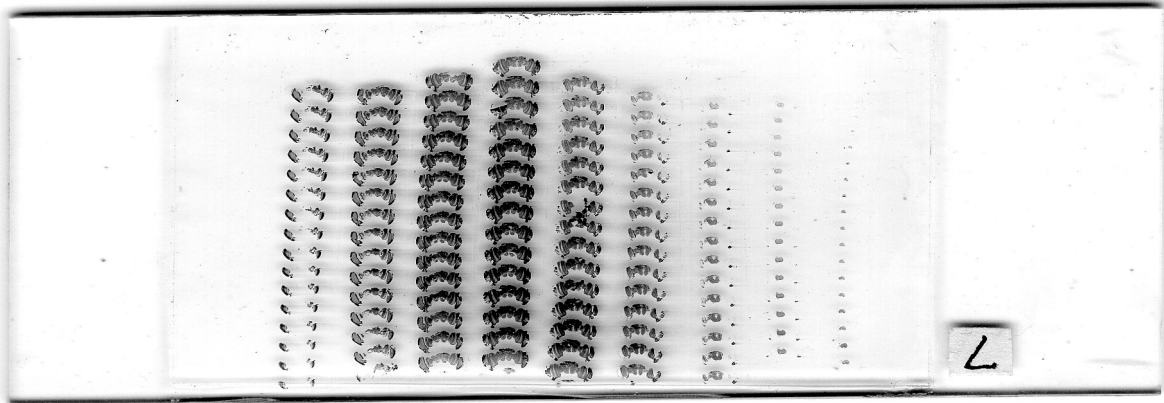

If you want to get the maximum of biology out of your microscope, you have to be as interested in the microscope as you are in the biology. High-correction lenses give high resolution, but the plane of focus is so thin that most of the subject is out-of-focus anyway. "Plain" achromatic lenses are totally adequate, even for color photography. When the Psychology Department shut down their physiology lab, I asked the Chairman if I could have the microscope, a once-beautiful ZEISS research scope. A few days later, he told me he had searched the records and the lab, and could find no evidence of a microscope anywhere. I took it home. The first thing I had to do was turn it upside-down to pour out the milky liquid inside.

When I got the scope, the 100x objective had been so mistreated that it was useless, probably from being left in a puddle of immersion oil for months. I called up ZEISS in their NY State office, and asked if they had one. The technician couldn't believe that the numerical aperture was 1.30, but the mark was too clear to be mistaken. Then he asked if the base had straight sides. No straight sides. "My God", he said, "The scope was made during the forties, maybe during the War". He told me that ZEISS had to throw out most of their objective lenses because they couldn't make back in sales what they had to pay in taxes for keeping them in stock. Then he offered to look around. In the back of a drawer, he found an orphan 100x objective lens that someone had overlooked. I bought it. The 1500x close-up photo of nerve cells in the brain of a honey bee was taken through that lens.

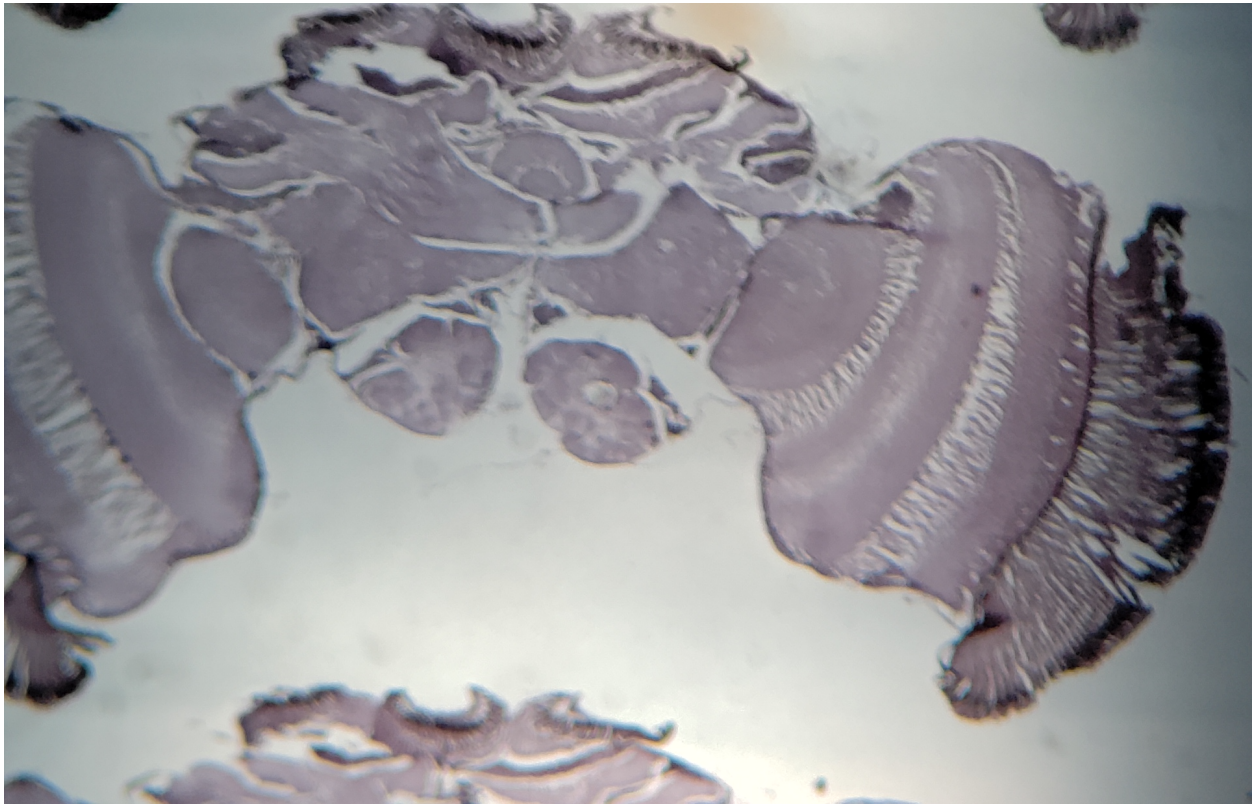

This photo shows one paper-thin section of a honey-bee's brain, stained with silver. At the extreme right is the eye with its columnar eye-units, or ommatidia. It is the separate nature of the light detectors that is responsible for the idea that the bee's vision must be like a low resolution newspaper photo. Just medial to the eye is the first optic ganglion, retaining much of the eye's columnar structure. The nerve cells of the second and third optic lobes are increasingly interconnected with collaterals, until the center of the brain is reached, which is a pure feltwork of neurons. My guess is that the progressively more interconnected tissue produces progressively more integrated information, generating a smooth visual image like the one that we experience. Histology and photo by the author.

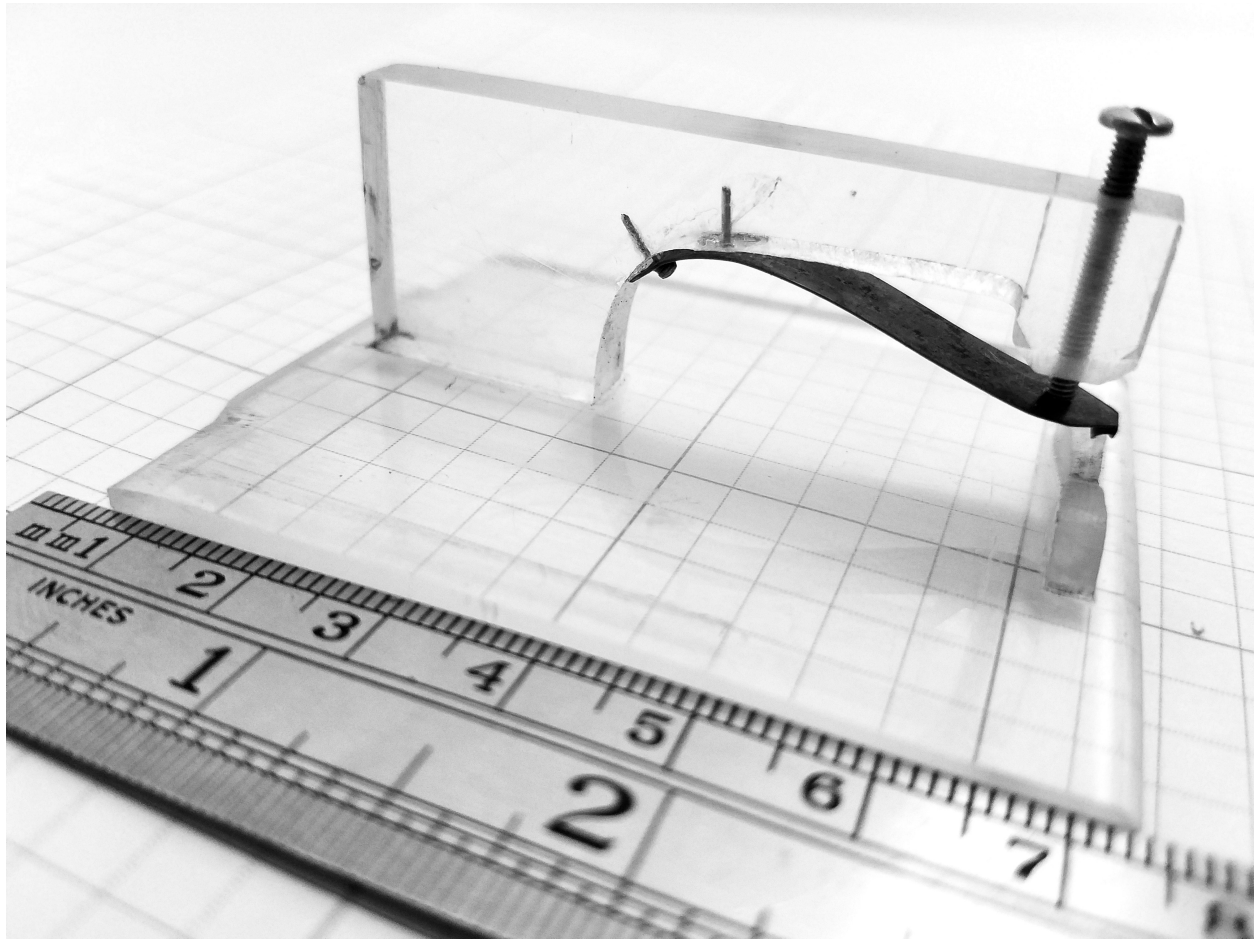

Bee Head Holder is a plastic arm equipped with a steel spring that holds a dome-shaped grip (at right), fitted to the top of the bee's head. When the bee is anesthetized with CO₂, the tongue can be flipped out, and will stay in place. The tongue is then inserted into a hole in the bottom part of the head holder. By turning the screw in the plastic arm, the dome-shaped grip is lowered onto the top of the bee's head, holding the head stationary.

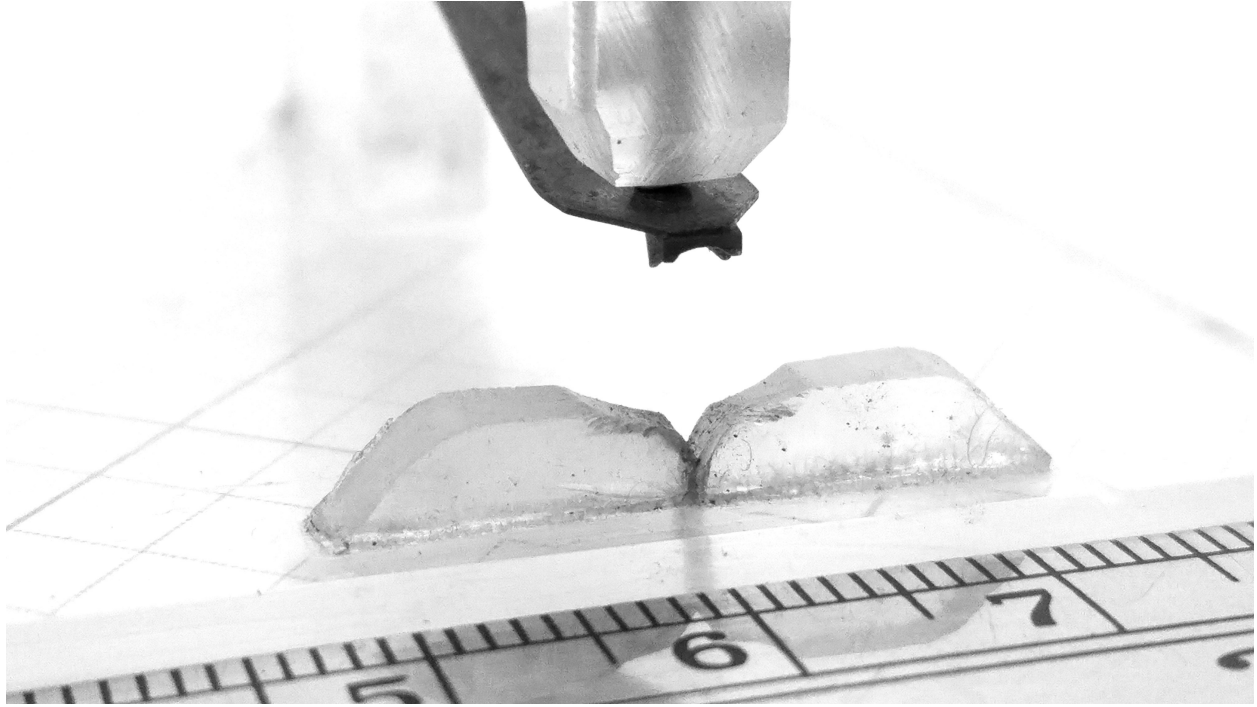

Close-up view of the bee head holder. In the photo, the dome-shaped grip fitted to the top of the bee's head looks like a tooth at the end of the steel strip. The hole for the bee's tongue is between the two plastic blocks. The six-inch line points to it.

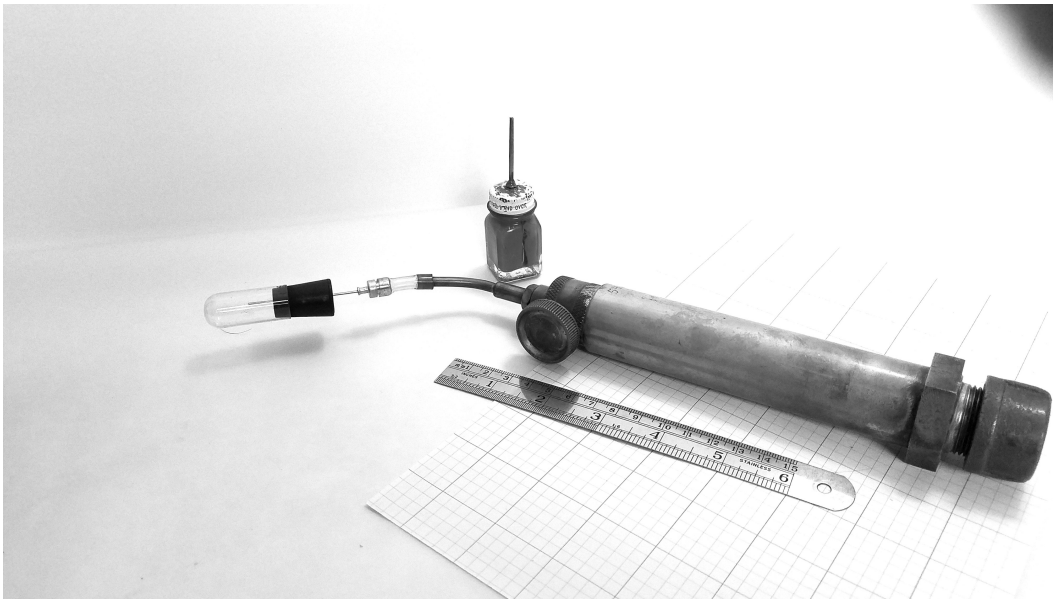

(Above). Bee Anesthetizer. By dropping in a few grams of dry ice and letting them come up to room temperature, the brass tube (at right) is filled with CO₂ gas, which is an anesthetic to insects. The CO₂ is then dispensed through a hollow needle into the test tube, at left, which holds the bee. A valve borrowed from a blowtorch turns the CO₂ on and off. Bottle at top holds paint for marking the bees. Note toothpick paintbrush. The ruled part of the scale is six inches.

(First Figure, below). Whole mount of honey bee brain, width 3 millimeters. Note eyes at extreme left and extreme right. At top of brain are three ommatidia, light-meters for the brain. Below the ommatidia are the four mushroom bodies, and central to the eyes are the optic lobes. Cerebrum at center. Note tracts of nerve fibers.

(Second Figure, below). Fiber tracts at center of bee's brain, connecting the two sides. 40x ZEISS water-immersion lens. Histology and photo by the author.

(Third Figure, below). Nerve fibers in optic lobe of honey bee. Histology and microscopy by the author. Magnification 1500 diameters. ZEISS 100x oil-immersion lens, mentioned above. Histology and photo by the author. Note columnar structure reflecting the eye, and collaterals.



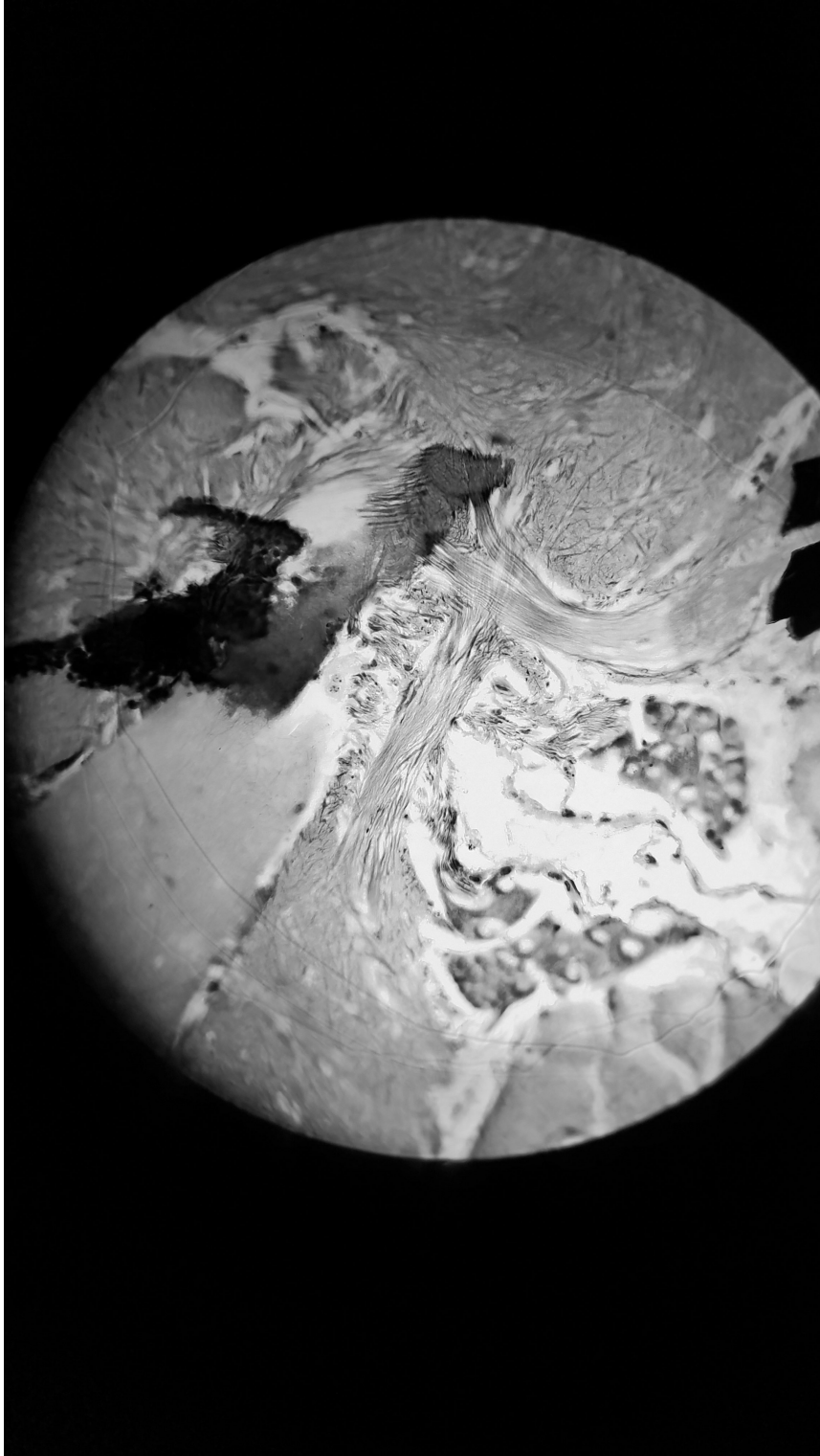

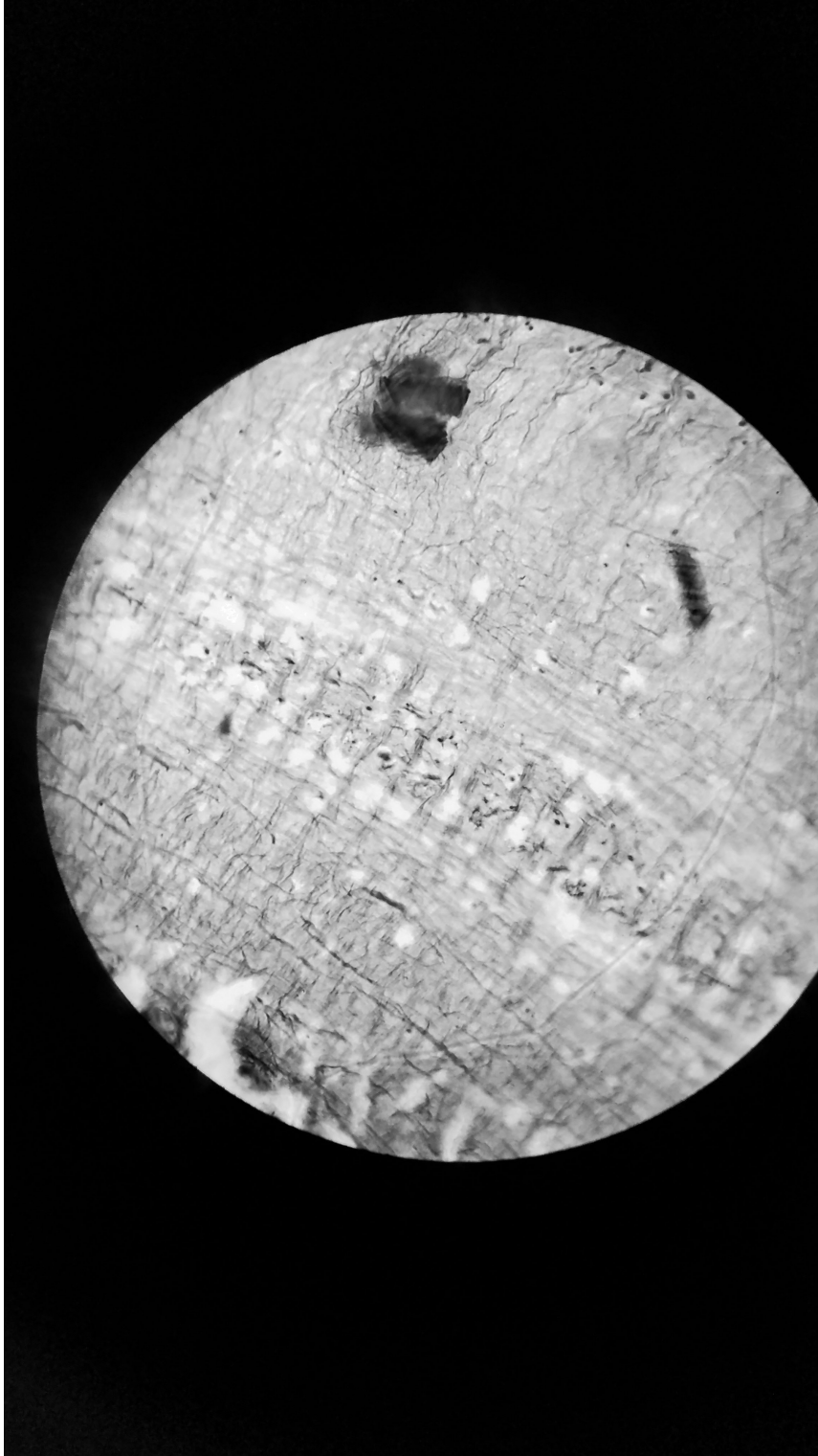

In my last semester, when, in spite of Noam Chomsky at MIT, my institute of technology decided that linguistics has no place in an institute of technology, I taught a course in comparative zoology. I laid out what I knew about insects and vertebrates, comparing the anatomy of marsupials with that of placentals. The apex of convergence was the skull of the thylacine, the Tasmanian wolf, whose skull is almost indistinguishable from that of a placental wolf. I was still thinking in evolution, but I saw massive convergence.

Any early animal that had to approach a food source would have all its sensory receptors concentrated at the leading end. Eventually, the result would be a head and a brain, in a process called cephalization. The obvious design of a large animal is a suspension bridge, with the internal organs suspended from it, like a stegosaurus. I postulated that animals on other planets would be subject to the same conditions as on Earth, so the animals would be generally the same as on Earth.

Stephen Jay Gould was just arriving at his “replay the tape” model of evolution based on the Burgess Shale deposit in Canada, under which, if evolution could start over again, and “replay the tape”, living things would turn out to be completely different from what they are. Gould never created a convincing bestiary of alternative animals, but I happened to be visiting a distant cousin in Cambridge who was a grad student of Gould. When I told her my idea, she told me, “You have discovered The Great Chain of Being”. And when I told Gould my idea, he told me, “You have discovered The Great Chain of Being”. I submitted a manuscript to a journal or two, but couldn’t even get it rejected. I suppose that the editor(s) still hold the copyright. The idea is standard now, in 2020, but not in 1980.

Runaway convergence was interesting, but not basic enough to be worth fighting for. Later, in 1999, when I found something that I knew was worth fighting for, the observation that equations are sentences, and the consequences that proceed from that, it took me six years to get it published. Even then it was in a book, not a journal article.

The Tone Wheel

Many years later, while preparing the manuscript for my 2005 book (*Structure of Matter, Structure of Mind*. Sofia: Pensoft; Philadelphia: BainBridgeBooks), I showed my manuscript pages to MSK, describing my graduate adviser’s wartime heroics. Michael said that he would ask Franklin S. Cooper to tell him how the Tone Wheel was made. As it turned out, it was Cooper who made the Tone Wheel by spinning a circle of X-ray film on a lathe, and exposing concentric circles of the film to sinusoidally varying illumination from a grain-of-wheat light-bulb. Then he developed the film. My adviser had nothing to do with it, and Franklin S. Cooper died just a couple of months after reporting to MSK. I had snatched the story of the Tone Wheel from oblivion at the last moment, and was proud of that, too. It pays to find out. As the geologist Bert Woodland told me, “There’s no substitute for knowing”. My old adviser had lied to me, seizing the moral high ground by presenting himself as a scientific war hero, when in fact he was none. The other graduate students asked me why I didn’t study syntax. I told them “I will, but I have to come to it in my own way”. I still don’t know whether I was lying then or not, but I did come to syntax, thirty years later, and in my own way.

Twenty years later, when my ideas were better developed, I was passing through Madison, Wisconsin, and checked at every book-store, looking for a copy of Hugo Iltis's *Life of Mendel* [Allen and Unwin 1966]. At the very last book-store, I told the enormous, bearded man behind the counter that "I am trying to solve the mystery of language, and the gene is the closest thing in nature to language. I want to get as close to Mendel as I can". The enormous, bearded man looked down at me and said, "I wasn't going to sell it. I was reading it myself. But you're the right buyer." He reached under the counter, and brought out the book, and slammed it down on the counter with a bang. "Twenty-five bucks" he said. I bought it.

Later, at a symposium, I ran into Hugh Iltis. I told him, "You are the son of Hugo Iltis. If I bring you my copy of your father's book, will you autograph it for me?" He told me, "Next time you are in Madison, come to the Herbarium". I did. It was on a Friday, and they were having a birthday party for one of their staff. I got a slice of cake, a cup of punch, and Hugh Iltis's signature on his father's book: *To William Abler, historian of science* it read. "That's my copy", he said. "The book-store guy talked me out of it".

Honey bees and lateralization were not the answer, so I abandoned them and decided to look at dinosaurs. This was 1980. Dinosaurs are still the most successful group of land vertebrates ever, having ruled the Earth's calorie-exchange for 160 million years. If language evolved by natural selection, the same selective pressures must have exerted themselves then as now, so there must have been some convergence. Dale A. Russell made his dinosauroid (*Syllogeus* 37, 1982), while Carl Sagan stuck the *Stenonychosaurus* onto Harry Jerison's graph of brain-weight-versus-body-weight. But brain weight isn't a theory of language, either. I signed on as a palaeo with what was then the Provincial Museum of Alberta (now the Royal Tyrrell Museum at Drumheller) summer excavation in the Red Deer River Valley of southern Alberta.

That was the summer of '82, the wildest on record. I hitch-hiked all over southern Alberta and northern Montana, and slept in the ditch by the side of the road many times. (This is not recommended for everyone. If you try it, make sure that no one knows you are there. It is not enough that they don't know where you are. They mustn't know that you are there at all. I have been found by dogs, never by people.)

The mosquitoes were so thick that year that if you stuck your hands in your pockets and put on a veil, and sat still for twenty minutes, you would be so covered with them that you looked like a carpet of mosquitoes. Trying to hitch from Dutton to Choteau, I couldn't get a ride from a Model T filled with partiers in 1920's costume, but a policeman stopped who told me, "The last two hitch-hikers I stopped for told me they were Jesus Christ and tried to beat me up." I promised that I would do neither, and got the ride. His buddies at the station stared at me through the window as I unloaded my pack from his car. I became the first person to walk in to Jack Horner's camp at Egg Mountain, where the baby dinosaurs and the eggs were buried. As I was on my way in, the women palaeos sang to me out the window of their car as they passed by, "Only the lonely get laid" –a parody of a popular song. Dinosaur Jim Jensen was there, telling us that his discovery of a hadrosaur jawbone in Antarctica

tipped the balance of acceptance to continental drift. You could see the nests, and you could tell you were on the scene. But sixty-five million years of burial had drawn seven veils of mystery between us and the *Maiasaura*. I hitched a ride from a poker gambler who told me, "It's better'n havin' a job. They just passed a Wild-West law. School-teachers and college professors are quitting to play poker against the tourists". He drove his car barefoot, and held his bottle of beer out the window so the passing breeze would keep it cool. He wore eyeglasses as thick as Coke-bottles, and slapped his hand on the dashboard as he said, "Dinosaurs? I always wondered what happened to them suckers". I saw the right front wing of a Glover's silk moth lying on the ground. If I had known then that you can attach it in your notebook with a drop of glue at the hinge, I would have it still.

I hitched a ride with the Alberta Provincial Egg Inspector and his son. We visited the egg boss at the Hutterite colony. The egg inspector said he had found a Reaumur thermometer in a barn, and told the farmer it ought to be in a museum. "Next time I won't be so honest" he added. Once, I even got a ride from a dentist. One night, when I was camped in my tent in a field, a lightning storm came up, creeping closer and closer. I could judge the distance by the time between the lightning flash and the thunder crash –five chimpanzees to the mile. The storm came so close that, even with my eyes toward the ground, buried in the crook of my arm, the light was blinding –but I didn't get hit. I saw rattlesnakes and wild rivers that seemed to flow uphill, and stood at the top of vertical cliffs –and the only time I was afraid was having breakfast in a diner. The man sitting next to me at the counter craned his neck and looked out the window and asked, "Which car is yours?" "I'm hitching" I told him. He leaped to his feet, and looked down at me and shouted, "You're a hitch-hiker?" When they heard that, everyone else in the diner leaped to their feet, too, and looked straight at me. I couldn't run and I couldn't fight. I knew I had only the time it takes to draw a breath to think of a way to make them laugh. I was so scared I don't remember what I said, but it worked. After the man left, the waitress came over and asked me, "Do you know who that was?" "No." "The most powerful rancher in the territory."

At the Coutts-Sweetgrass crossing, the Canada Immigration Officer first questioned me, and telephoned the Director of the Palaeo Camp, then stood next to me at the door and dictated my answers to the questions from the Customs Officer: "Do you have anything with you that you bought in the United States?" "Say No!" ... "Say No!" Then he asked me if there was anything he could do for me. "Yes. Tell me the best place to hitch." He did.

I worked on the tyrannosaur excavation in the Crowsnest Pass, with its Seventh Heaven Aquatic Sensorium Waterbed Store, and where tourists asked us whether we prospect on horseback or by airplane. We told them that the tyrannosaur was killed by an ambulance. The quarry was on a cliffside. One of our crew was enormously big and powerful. We would break off a huge chunk of rock, maybe 3-feet by 2-feet by 2-feet, and when the quarry director wasn't looking, our friend would hoist the rock to his chest. Then, teetering on the edge of the precipice, he would let himself tip past the point of no return, and push the rock out to infinity –and himself back to safety. We

visited the homestead of Happy Jack Jackson, the unhappy badlands cowboy whose abandoned cabin now has cactus growing on the roof. There used to be a rifle in the attic. The story I got is that he came north across the border around 1900 at the invitation of Federal Officers, on suspicion of murdering his girlfriend's other boyfriend in Texas. It would be impossible, without re-printing it entire, to capture the poetry of loneliness conveyed in Happy Jack's diary, which contains only a few words for each day. I include here, in chronological order, a few lines taken from the years 1909-1921. (AB Jackson, "Happy Jack" Diaries of Hansell G. "Happy Jack" Jackson, 1909-1942. Glenbow Museum, Calgary T2G 0P3, Alberta, Canada. With kind permission, Doug Cass, Glenbow Museum):

"Mosquitoes is Hell ... Rain Dam the Rain ... Drunker than Hell ... Sick Poor Boy ... Found Big Foot [cat] Murdered by Wild Beast of the Jungle ... McClung Family driv up [Nellie L. McClung was the Carrie Nation of Canada. See her book *In Times Like These*, New York: Appleton, 1915] ... Dan the World By Sections and Hell By Town Lots ... Prohibition Starts [in Alberta]. Hurrah for Hell ... River Went Tight [froze over]... No Booze Beats Hell, Hurrah for Nellie McClung ... Waiting for sonething to Happen ... The World is Dried up as to & Water & Booze Boath ... Hurrah for Hell and High Water ... 58 below [zero] Sunny Alberta ... Sternberg was here [Charles Hazelius Sternberg. See his 1909 autobiography *The Life of a Fossil Hunter*. New York: Holt] ... "

Happy Jack was trying to keep out of sight, but made the mistake of donating money to the local school so the children could take the bus to Calgary and hear the symphony. The result was that he became famous, and on Sundays, dozens of tourists would bring their picnic lunches and spread their blankets around Happy Jack's cabin. So much for keeping out of sight. A local rancher told us how to make a saddle: "First, you catch an old orangutang cow. I have this one [a saddle] sold as soon as I can finish making it. When the Prince of Wales came across Canada on tour, he bought a walking stick from a rancher and said, "I wouldn't think of giving you a check", and the rancher told him, "And I wouldn't think of taking one"". What people will do for a line. Like Diogenes telling Alexander "Stand out of my sun", the Prince's signature on the un-cashed check would have been a better souvenir than a few dollars.

We spronked the high badlands during the day –a kind of boot-skiing– and at night, when it was raining, we would venture out again. By moonlight, in the rain, the badlands became a fairyland. Recent bone gleamed as if radioactive, and owl skulls winked at us. When wet, the bentonite surface was like toothpaste, so slippery that you couldn't walk up a two-degree slope. You had to crawl on your hands and knees and climb with your fingers. Sinkholes became fountains, shooting parabolas of water thirty feet across the badlands. We reveled in the word palaeoaeolian, ancient winds with more vowels in a row than queue. There was a rotating storm like a horizontal wagon wheel in the sky, with lightning flashing between the spokes, and rain pouring down from them.

I excavated a huge humerus on a cliff in the high badlands, and when it came time to bring it home, I realized that I would have to bring it myself. That meant bringing the bone in its plaster jacket down to flood-plain level, then across to the river, and the canoe. To keep the weight of the plaster jacket to a minimum, I plastered over only one side, and slid the half-jacket down the cliff like a boat. But carrying it to the river and the canoe was a different story. The jacket must have weighed as much as me, so I kneeled in front of it, and leaned it against my back, and rocked myself forward, so the jacket rested on my hips, without me having to actually lift it. To avoid walking even one inch more than necessary, I walked my path to the river, and planned the easiest route, and placed my canteen ahead of me as a target to walk toward.

This performance attracted the attention of a herd of cows, who lined up shoulder-to-shoulder to watch me. I was scared, because I didn't know what they would do, but I had no choice but to carry on. In the end, all they did was watch me.

One time, walking along a road, I was startled to attention by the deafening buzz of a rattlesnake. It was huge, five feet long, I guessed, and ready to strike. But by the time it started rattling, I had already passed it, and was no longer a danger to it. Once you know where they are, snakes are easy to kill. I didn't harm the snake, but learned a lesson about it. By rattling after I was already past, all the snake did was to announce its presence, practically inviting disaster. The snake was fierce, but not smart.

One year, the women palaeos anointed themselves the slime-hags after a kind of sea-lamprey, and appointed me social director, which meant that I had to organize a scientific lecture series for Palaeo Camp. I didn't tell anyone, but my principle was to present science at the highest possible level so that, even if the youngest palaeos didn't understand everything, the lectures would give them a star to steer by. I once had to threaten to throw out a speaker bodily when he offered to deliver watered-down science. At the end of the season, when one of the young palaeos told me, "I didn't understand everything, but the lectures gave me something to work toward", I knew I had succeeded.

Hitch-hiking home, a family let me out at the Winnipeg off-ramp from Trans-Canada Highway 1, at midnight. I could see a tall, thin man with long, flowing grey hair silently dancing the Viennese waltz solo under the street-light in the distance. I quietly walked around him across the field, and settled into the ditch for the night, within sight of distant houses with lighted windows. More than I can tell here.

One time, at the Museum, I wanted to check whether the teeth of a Dimetrodon in a glass display case were serrated or not. The Exhibits Manager would have been happy to open up the case and pull out the skeleton, and let me have a look. But that would involve time, and risk to the specimen. I realized that the distance from the glass to the teeth was about two feet, and that the Geology Department instrument cabinet contained the lens from an American Optical cycloptic microscope, and some eyepieces. The optical path inside the assembled 'scope is pretty long, so it should be possible to rest the front of the lens-housing against the glass of the case, and use the

eyepiece to make a short-distance telescope. It worked (the teeth were serrated), and everyone agreed I had pulled off a regular MacGuyver.

Dinosaurs

At that time, the Canadians were focussed on a “museum quality” standard for their fossils, and my 1984 paper A three dimensional map of a paleontological quarry, *Contributions to Geology*. (University of Wyoming, Laramie. 23(1):9-14), was my attempt to convert them to taphonomy, the science of how living things die and become fossils. I think that worked, too. Figuring that the tooth is the point of contact between the predator and its prey, and that the tooth would hold unexpected information on behavior, I set out to study the teeth of the dinosaurs. The result, Abler, William L. 1992. The serrated teeth of tyrannosaurid dinosaurs, and biting structures in other animals. *Paleobiology* 18(2):161-183, actually made me famous in dinosaur circles, but by 1985 I realized that the study of dinosaurs was not a theory of language, and in my mind, I had dropped it already. I finished the tooth study because it was the greatest scientific fun ever, and my last dinosaur paper was published in 2013. I made thin-sections of tooth serrations, and built specialized dynamometers to compare the cutting power of the teeth of sharks and tyrannosaurs to hack-saw blades and artificial steel teeth. You can't, say, double the length of the serrations on a real tooth to carry out a controlled experiment, but you can do that with specially-made steel teeth. Blessings to Francesco Redi. The particulate principle isn't a controlled experiment, but the theory was possible through method.

To show that I am serious about my foreign language studies, I include an abstract, in Chinese, written by me, of my serrated tooth studies. I can't read it any more, but I could read it when I wrote it. A friend edited it for me. It is not perfect, but it is understandable. The calligraphy is mine. 1992. The three characters in the middle of the title, following my name, are my Chinese name, Ai Le-shi.

食肉恐龍鋸齒狀的牙齒

On the serrated teeth of tyrannosaurid dinosaurs, with comparisons to serrated biting structures of other animals.

William L. Abler 艾樂詩

4234 North Hazel Street, Chicago, Illinois 60613, U.S.A.

ABSTRACT

[Tyrannosaurid] 恐龍側面牙齒呈彎曲的圓錐體，橫截面為橢圓形。在橢圓形長軸兩端有一雙鋸齒狀的排列。看起來，每一個鋸齒狀結構好像是一個小的充氣立方體。如果跟鋼刀刀切肉的方法比較起來，就可以明白有鋸齒狀的牙齒怎麼切開肉食。普通的鋸齒狀鋼刀刀切肉

時是用一個扒跟撕的方法。

平滑的鋼刀刃切肉時，是另外的一種方法：就是把很大的物理力集中在小的地方上。

[Tyrannosaurid] 恐龍牙齒切肉的方法最像平滑而鈍的鋼刀刃。牙齒長軸比移動的方向偏了一個小銳角時，牙齒切肉的方法就跟稍微尖銳的鋼刀刃切肉的方法很像。兩個鋸齒狀之間的空隙像一個有磨擦力的小老虎鉗，可以起到扒住肉裏纖維的作用。這些空隙也作細菌住的港口；

[Tyrannosaurs] 用這些細菌幫助征服他們的受害者。[Troodon] 牙齒

有明顯的鋸齒狀結構；[Troodon] 那種吃肉恐龍的牙齒跟 [Carcharodon] 那種化石鮫魚的牙齒，切肉的方法跟鋸齒狀的刀刃切肉的方法一樣。哺乳動物切肉的牙齒有三種切肉的方法：他們用對牙刃的靜壓力，在上下牙齒中間軋碎肉就像剪刀的方法；[Tyrannosaur] 也用兩個鋸齒狀中間的老虎鉗磨擦力，正像哺乳動物切肉牙齒上的坑凹，用抓跟撕的方法，也用側面壓力切肉。因為他們有不同的，複雜的牙齒，所以古代的哺乳動物必然具有不同的，

可是鋸齒狀結構自己的起源還不明白。在一個病牙齒上有多條鋸齒狀排列表明鋸齒狀排列跟排列的地方有不同的起源。這是艾樂詩寫的。

I include here a photo of a thin-section of one serration on the tooth of an *Albertosaurus*, showing the junctions with its two neighbors, to its left and to its right. The two vertical parallel lines, about 2 inches apart in the Figure, are the junctions. Note that the junctions are flat, a rare condition in biology. Histological staining under ground has brought out anatomical features of the serration. Note the rounded hexagonal geometry of the serration interior, a compromise between biology and crystal growth. The thin-section was made by grinding one surface of the tooth flat, then glueing it down to a glass slide with cyanoacrylate, then grinding the other side down until the remaining tooth tissue was a thin sheet. Note the round ampullae at the bottoms of the junctions between neighboring serrations, postulated to protect the tooth from breaking. The exposed part of the serration is clear hydroxyapatite that has a different embryonic origin and different polarization from the serration interior. Each serration is about 0.5mm wide. Shown here is a separate print of Figure 12c of my 1992 publication. Histology and photo by the author.

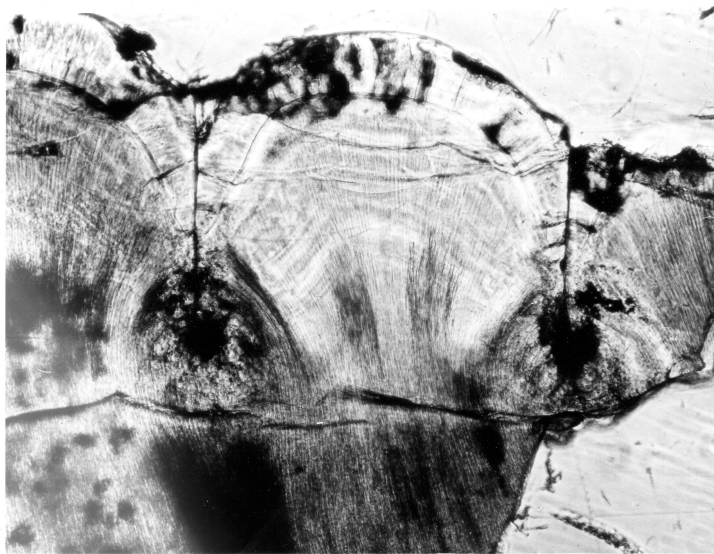

The Particulate Principle

Around 1985, I also realized that basic research into the theory of language was going nowhere. If this judgment seems irresponsible, I felt I had seen enough science to be confident in my decisions; and the subsequent success of *TLI* and the discrete combinatorial system shows that I was right. I had to have enough confidence in this idea, and in myself, to take the risk of looking for a remedy. And I was perfectly well aware that abandoning the tradition of solving puzzles in syntax offered no guarantee of success. I had to let go of everything I knew, and find a question that was outside linguistics as then understood, and that could be answered. The question that took shape was, "What is the absolute simplest property of language?" This wasn't a question in syntax or phonetics. It was abstract –a property– and entirely a matter of intuition and monumental luck. The word "property" carried an abstract meaning never intended by Harris or Hockett, but the right one. Harris taught that language is entirely abstract, but all he did with that was to insist that real-world knowledge must not be allowed to intrude into our linguistic descriptions. So, you couldn't say that we call nickels "nickels" because they are made out of nickel, but our task was clear: To describe language, not necessarily to understand how it works.

By addressing the question of discreteness as a property in itself, I had unintentionally (instinctively?) trespassed into the precincts of abstraction and natural law, where the real secrets of nature are hidden. The answer, the discreteness property of the phoneme, seemed so ridiculous that I had trouble taking it seriously. Nevertheless, the right answer was the discreteness property of the phoneme, and even then I had to force myself to think about it. Within a few days, however, the answers began to take shape. There was non-blending, and its consequences, the retention of identity and retrievability of the particles after combination. New properties emerged from new geometry, not from mixing and blending. New combinations with new properties could be constructed in vast numbers. There is an upper limit to the number of constituents in a particulate system –when there are too many constituents, they become indistinguishable from their neighbors, like a blending system– and a periodic property helps to circumvent the limit that is inherent in a one-dimensional system. These laws apply universally. They must not be imagined as something that happens in one specific system or another.

Certain reports to the contrary, I didn't extend Fisher's particulate reasoning from the gene to the phoneme. Such material analogies aren't abstract, and would not have led to the formulation of a universal law. I reconstructed all of Fisher's logic by looking only at the property of discreteness. It was only later that I realized that my logic was identical to Fisher's, and that it could be applied to the atoms in chemical combination, and to the symbols of mathematics. The surprise, and in some sense the confirmation, was the observation that the phoneme chart, with its repeating articulatory series from stop to labial to spirant to liquid to semivowel to vowel, duplicated from front to back, is a periodic table. Anyway, it is exactly as periodic as the table of the elements.

And this is what Pinker stole. A lifetime of acquaintance with the structures of nature, the strength and flexibility and weight of materials, the flow of heat, evolution

and its mechanisms. The intuition to know when things are right. These are so far beyond Pinker's poor ability to understand that he doesn't know they are there. He just explains what is in front of him.

Drama in Science

Why would Mendeleev choose a word like "periodic", which implies something mathematically continuous like a sine wave, when he knew that "there is nothing between the elements"? One of the objections to the idea of a periodic law was that the properties of the elements aren't continuous. I would have to guess that Mendeleev loved dramatic language as much as anyone. After all, even the hard-headed mathematicians have called numbers that can't be expressed as the solution to an equation with integer exponents and integer coefficients "transcendental". A magical, mystical word. Mendeleev might have saved himself, and me, a lot of trouble by calling his discovery "the table of repeating properties of the elements". But, like Eugene Wigner choosing "unreasonable effectiveness of mathematics" instead of "appropriateness of mathematics", or John Milton choosing *Areopagitica* instead of "Essay on Freedom of the Press", he couldn't resist the most dramatic, and most memorable, word that he could find. The point isn't scientific precision, but drama and recognition value. If Unreasonable and Periodic and Transcendental and *Areopagitica* are misnomers, let's make the most of them.

Fundamental Theorem

And the observation that the particulate principle applies to the atoms in chemical combinations showed that it was active before the origin of life, and is more basic than anything in biology. The particulate principle is a matter of physics. That is why Pinker strategically leaves atoms and chemical combinations out of *TLI*. His explanation (page 85) "It may not be a coincidence that the two systems in the universe that most impress us with their open-ended complex design –life and mind– are based on discrete combinatorial systems", is a gleaming example of a misleading statement without actually lying. After reading my paper, Pinker knew well enough that atoms in chemical interactions fall under the particulate principle. Pinker's next sentence (*TLI* page 85), "Many biologists believe that if inheritance were not discrete, evolution as we know it could not have taken place" is curiously tentative, as if Pinker is trying to distract the reader from noticing the universal importance of discreteness. All responsible biologists realize that the particulate property of the gene is the fundamental property of biology, without which variation and selection would not lead to evolution.

The Mind's Eye

The theory of the particulate principle was an exercise in the use of the mind's eye, for which there absolutely could not have been a better exercise than my 1973 book. It was *The Sensuous Gadgeteer* that wrote the particulate principle and quantum-Newtonian theory. Maybe it sounds too simple, but the book is a comprehensive grand tour of the mental images that you use in making things. It showed what happens when you sharpen a blade –you reduce the radius of curvature at the edge. If you polish a surface before it is smooth, you will end up with a surface

covered by scratches that have polished sides. It showed what happens in cutting. It showed the use of molds, lost-wax, the imagining of negative space. The un-seen action of saw teeth inside the wood. What you see, and what you have to imagine. But mostly it showed the exercise of the mind's eye in going through the motions of designing and assembling a device, so that you don't make mistakes that are expensive both in time and money –so you have a workable design before you start. My dynamometers for the study of serrated teeth were designed on that system, starting out as perfectly balanced and suspended beams, until I realized that the instrument doesn't have to be perfect. It only has to produce a measurement that is bigger than its margin of error, a signal that is greater than the noise. I was eventually able to make a plastic model of the serrations on the teeth of *Albertosaurus*, the most sophisticated I have seen, and I have seen a lot, even *T-rex*. The properties of discreteness –isolation of the particle from its surroundings, non-blending, retrievability, production of new properties through new geometry, limits to the number of particle-types in a single system, the value of a periodic property– may have to be expressed in words, but they all came into being by manipulating images in the mind's eye –a habit that I had cultivated all my life, but sharpened and organized in *The Sensuous Gadgeteer*. Even the theory of truth-and-falsity, which I published in *Science Progress* 93(4):403-427 (2010), was an exercise in mental imagery, the ideas drifting into their places like the tokens in a game of Tetris. A self-diversifying system was, in effect, a device constructed by nature –and the element of luck is overwhelming, even there.

Pinker (*TLI* pages 70-71) reports on creative people who think in mental images, but he apparently can't think in them himself.

Once in possession of a theory of discreteness, Professor Pinker, in his greed, determined to take everything by constructing the discrete combinatorial system. Here was a complete, comprehensive theory of language in a single phrase as catchy as "Meet me in St. Louis, Louis", or Johnnie Cochran's, "If it doesn't fit, you must acquit". The discrete combinatorial system has practically run away with contemporary linguistic theory, but its disproof in 1957, by Pinker's idol Noam Chomsky, was one of the opening observations in the modern era of linguistics. Paraphrase can make identical ideas seem new and different. The discrete combinatorial system is based on the theory that words are built by attaching phonemes to other phonemes, and sentences are built by attaching words to other words. The idea that "All you need to produce language is the ability to attach words to other words" is the same thing.

A One-Tune Fiddler

Chomsky is better at disproving things than at proving them. His transformational grammar of 1957, with its kernel sentences and its transformations, isn't terribly different from his recursive-embedding grammar of 2002, with its sentence fragments and its repeated recursive embeddings of one fragment into another. Transformational grammar collapsed for reasons that never were clear. No one asked why, and recursive grammar will fail for the same vague reasons. But Chomsky's disproof of the discrete combinatorial system still stands. On page 95 of his 1957 *Syntactic Structures* (Mouton, The Hague), Chomsky argues, in effect, that if words

were built by attaching phonemes to other phonemes, the same phonemes assembled in the same order would build the same word. “Such pairs [Chomsky’s examples] as “bank” (of a river) and “bank” (for savings)” would not be possible. Further, different phonemes assembled in the same order would build different words, and “such absolute synonyms as /ekinámiks/ and /iykinámiks/ (“economics”), “ádułt” and “adúłt,” would not be possible. Synonymous sentences are harder to find, but Chomsky offers the phrase “unmarried man” as a synonym for “bachelor”; and “discrete combinatorial system” is a good synonym for “all you need in order to generate language is the ability to put words together”. And Pinker himself (*TLI* page 217) informs us that, “most sentences are ambiguous”, in other words, the same words assembled in the same order don’t build the same sentence, disproving the theory of language as a discrete combinatorial system.

Search for a Question that can be Answered

In searching for a theory of language as-a-whole, I took the position that language is so vast, both in number of languages, number of potential sentences, and number of grammatical constructions in the world’s languages, that no examination of language would ever yield a solution. The question came down to this: Either find a model for language, or there would never be a theory of language, and we would just have to live with that. The idea that order could somehow coalesce out of swirling storms of nerve firings in 100 trillion or 1,000 trillion synapses seemed ridiculous. The brain itself couldn’t keep track of what it was doing. I spent ten years, from 1989 to 1999, looking for a model. I tried everything I could think of. Game theory, evolutionary spandrels and evolutionary replacement like the bower-birds’ nests, the idea that language is the origin of language, and that language is originating all around us all the time. Eventually all that was left was arithmetic. I remember the place on the floor where I was looking when this realization struck me. As with the discreteness property of the phoneme, the idea seemed too ridiculous to be taken seriously, and yet, arithmetic was the only thing left, so I forced myself to think about it. Within five days it became clear that equations are sentences, and I knew that the simplicity of the finding would invite ridicule. After many wrong turns, I eventually arrived at Newton’s equal-and-opposite as the mechanism that generates the symmetry of the equation and its relationship to physics.

At the time of writing *The Language Instinct*, 1990–1994, Pinker knew, or should have known, that language isn’t a discrete combinatorial system. And when he explains, (*TLI* page 363) “the possibility that there is an undiscovered corollary of the laws of physics that causes brains of human size and shape to develop the circuitry for Universal Grammar seems unlikely for many reasons” and again on *TLI* page 364, “The pitiless laws of physics are unlikely to have done us the favor of hooking up [brain] circuitry so that we could communicate with one another in words” he knew that exactly such a law had been discovered, and, in mutilated and diminished form, was the basis of his entire book –the particulate principle of self-diversifying systems (Abler 1989). I knew intuitively that the particulate principle was only half the story of language, and, very reluctantly, let go of it and set out to find the other half. Again with no guarantee of success. But in his greed, Professor Pinker had to have it all, and

proposed the discrete combinatorial system, which he found in the caption to Figure 1 of my 1989 paper. With his (*TLI* page 84) technical-sounding “sampled” and “permuted”, he makes it sound so sophisticated. But “sampled” and “permuted” isn’t a theory of the sentence, any more than a “discrete combinatorial system” –another name for “attaching words to other words”, and a description, not a theory.

The Thrill of Discovery

Despite his prodigious curriculum vitae, Professor Pinker will never know the thrill of discovery. As the concept of what was to become the particulate principle took shape, and later the Newtonian theory of the sentence, I had the sensation of rocketing back and back and back, while the structure of the system came increasingly into perspective. In draft after draft, re-written from the beginning, I watched the system simplify and take form. At first, the system looked to me like an Art Deco skyscraper in moonlight, then a crystal of rutilated quartz. Then the quantum property and equal-and-opposite. Sometimes I had so many ideas at once that I couldn’t write them down fast enough to remember them. I felt rich. Once, a few days after I had lost an idea, a yellow swallowtail butterfly appeared at the edge of my mind’s eye. I knew that it was the ghost of the lost idea. I sat at the table next to the window in the library and waited for it to come back. I felt like an explorer in a jungle, brushing past ferns, turning over stones, betting the years of my life against a solution. And if it was the same as Chomsky’s, I would just live with it.

Pinker is a straight-ahead thinker who is very good at explaining a system as it is presented to him, describing what he sees, never looking left or right. Never deep. He knows the thrill of explaining, and of tricking his readers, of re-telling other people’s ideas in finer language; of submitting fraudulent manuscripts and getting away with it, and speaking in front of crowds of his victims, while we rush to press our money into his hands. He uses vulgarity in front of audiences to show them that he can get away with what they couldn’t. Hitching your wagon to Pinker’s star may be a shrewd career move now, but, like Carl von Naegeli, it will land you in the history books for all the wrong reasons. The future is watching. Everything depends on what you want –a comfortable life, or the secrets of nature. You can’t serve two masters.

Anything Valuable

Any time there is anything valuable, anything at all, there will be someone waiting to steal it. Diamonds, fine art, the Tour de France, plywood –anything. Even discoveries in science. As a law in physics, the particulate principle was both invaluable and intolerable to anyone whose life had been dedicated to the biology and evolution of language. Eager graduate students, dreaming of prestigious professorships, rich government grants and exotic foreign travel, would go into debt for hundreds of thousands, following their Pied Piper. Even if they didn’t realize it, P&B 1990, and *TLI* 1994 were leading the way. With their whole life invested, they would never let go.

I remember how I came to *The Language Instinct*. After realizing that the particulate principle was only half the story of language, I reluctantly let go of it, and started searching for a model for syntax. But I wanted to know the current state of thinking on syntax, so I called up some of my old friends from linguistics and asked for a lead. One of them had taken a job in a bank, and hadn't kept up. But another was a professor of Linguistics. He suggested, "Get Steve Pinker's new book *The Language Instinct*". It wasn't that easy. Chicago was sold out, but I was on my way to Minnesota, and found a copy in a bookstore in Minneapolis. \$29 exactly. I bought it. The next day, in Aunt Martha's [not her real name] kitchen, I started reading.

Smoke Screen

Like everyone else, I was carried away by Pinker's charming prose, and by his vivid portraits of heroes great and small who people the story of linguistics, giving it its color and personality. While Pinker's whole book (see above) is filled with irresistible stories, the pages before his theft of the particulate principle have already established the pattern:

The Language Instinct 1994, Famous Personalities:

FAMOUS WRITERS such as George Bernard Shaw (3 of them), pages 18, 70.

FAMOUS SCIENTISTS such as Michael Faraday (12 of them), pages 19, 24, 49, 70, 71.

FAMOUS PSYCHOLOGISTS such as William James (10 of them), pages 20, 21, 23, 31, 62.

FAMOUS LINGUISTS such as Noam Chomsky (42 of them), pages 21, 22, 23, 24, 27, 29, 30, 31, 33, 35, 36, 37, 38, 39, 40, 41, 42, 43, 46, 47, 48, 49, 50, 51, 52, 57, 58, 59, 60, 61, 63, 64, 65, 68, 69, 70, 72, 78, 79, 83, 84.

PROSPECTOR Michael Leahy (just one), pages 25, 26.

FAMOUS EXPERIMENTAL SUBJECTS such as the K's (11 of them), pages 26, 29, 30, 31, 36, 38, 39, 40, 44, 45, 46, 47, 48, 49, 50, 51, 52, 53, 67.

FAMOUS THINKERS such as Socrates or George Orwell (10 of them), pages 27, 55, 56, 58, 73, 74, 75, 77, 78.

FAMOUS FIGURES IN ENTERTAINMENT such as Mickey Mouse (9 of them), pages 31, 32, 42, 43, 52, 58, 69.

FAMOUS PUBLIC FIGURES such as Catherine the Great (6 of them), pages 33, 57, 62, 68, 83.

FAMOUS ANTHROPOLOGISTS such as Margaret Mead (3 of them), pages 59, 65.

Inevitably a list like this one is approximate, but the point is clear: *TLI* is generous in its inclusion of fascinating people in every imaginable capacity. Nearly every page includes some interesting mention, many pages include several. Pinker has been meticulous in seeking out every relevant contribution. His knowledge is encyclopedic. The reader can sense Professor Pinker's total grasp of his subject. In exhaustive detail, Pinker spells out for his readers exactly who did what, omitting nothing. Nothing, that is, except the author of the central concept that made *TLI* possible in the first place, the theory of discreteness, hidden in Pinker's descriptive phrase, the "discrete combinatorial system". I would have included a complete list of names and page-numbers. It would have been easier to verify, but it might have looked too much like an index, and could have been treated as plagiarism –mining Pinker's book for names. The moral? Strike first! The plagiarist has all the advantage.

But no mention anywhere of the real author, Pinker's pages 84-85, of "In a blending system the properties of the combination lie *between* the properties of its elements" (Pinker's italics) (after Abler 1989, page 1); "In a blending system, ... the properties of the elements are lost in the average or mixture" (after Abler 1989, page 2); "... *blending systems*, like geology, paint mixing, cooking, sound, light, and weather". (Pinker's italics) (after Abler 1989, pages 1, 8); "Many biologists believe that if inheritance were not discrete, evolution ... could not have taken place" (after Abler, 1989, pages 2 and 9-10); "A finite number of discrete elements ... are ... combined ... to create larger structures ... with properties that are quite distinct from those of their elements" (after Abler 1989, page 2); "The first is the sheer vastness of language" (after Abler 1989, page 2); "A finite number of discrete elements ... are sampled, combined and permuted to create larger structures ...; "discrete combinatorial system" (after Abler 1989, page 4); "the range of properties that can be found in a blending system are highly circumscribed, and the only way to differentiate large numbers of combinations is to discriminate tinier and tinier differences." (after Abler 1989, page 9) Only 150 words. Enough to show that language is the solution to a problem in engineering (P&B 1990 pages 712, 714; *TLI* pages 83, 127), but not enough to show that the particulate principle is a law in physics.

Missing Person

By the time we reach *TLI* page 84, Pinker has made us so accustomed to seeing the fascinating persons and personalities that people the study of language that we don't notice the one missing person. As I read pages 84 and 85, I remembered the story of the Union soldier, marching with his regiment in the Civil War, beginning to recognize the familiar landmarks of home. He was pardoned for AWOL by President Lincoln. When I read, *TLI* page 85, "In a blending system the properties of the combination lie *between* the properties of its elements", I felt the hairs stand up on the back of my neck like I was being eaten alive by a mad dog. "This is me. Where's the reference? Where's the reference?" I knew I was had. I examined the text for references, and found no numbered or dated ones. I looked in the back of the book for end-notes, under Pinker's "In a blending system ..." and found nothing. I looked for "Abler" in the end-notes and the Index, and found nothing. At last I found my name,

“84. Discrete combinatorial systems; Chomsky, 1991; Abler, 1989; Studdert-Kennedy, 1990.”

sandwiched, and hidden, between a very famous scientist, and a scientist well-enough-known among linguists, and misdirected away from the real observation, “between, rather than outside”. Ever since that moment, Pinker and I have been brothers under the skin. The only two people in the world who know that language gets its structure from physics, the only two who understood his role in hiding it, and the only two who understood his theft. I knew I was dead.

I also knew it would take me years to understand what Pinker had done, and to unravel how he had done it. To get a start, I tried to talk it over with my friends. Here is a sample of what I got:

One friend told me, in an angry voice, “You’re still alive!”

Another friend told me, in an angry voice, “Bill, Do something else!”

Another friend told me, “If you want to make an omelette, you have to break a few eggs.”

Another friend told me, “I’d be inclined to do nothing.”

I called one of the agencies, either the NIH or the NSF (I can’t remember which), that Pinker mentioned in his Preface, and the woman told me, “This is outside our jurisdiction. You are free to publish your thoughts, and use truth as your defense”. I knew I was alone, but the woman’s comment raised another question. Pinker’s acknowledgment (*TLI* page 9), “My own research on language has been supported by the National Institutes of Health (grant HD 18381) and the National Science Foundation (grant BNS 91-09766), and by the McDonnell-Pew Center for Cognitive Neuroscience at MIT”, gave me the impression that the writing of *TLI* was sponsored by the NSF and the NIH and McDonnell-Pew, and had their prestige behind it. So the woman’s comment seemed out-of-place. But Pinker’s curriculum vitae says that his NIH grant was for “Language Learnability and Language Development” (competitively renewed 1986, 1989, 1994); and his NSF grant was for “Language Acquisition and Computation” (1 of 15 Co-Investigators) –not *The Language Instinct*. I haven’t seen the contracts, but I wouldn’t be surprised if they included some assurance that there was no plagiarism or misrepresentation of science involved. Pinker didn’t actually say that *TLI* was supported by the NSF and the NIH, so he is safe. You don’t want to get caught committing plagiarism on Uncle Sam’s dime, but I would imagine that there is something about plagiarism and fake science in Pinker’s contract with Morrow.

In 2007, Pinker was elected a Fellow of the Linguistic Society of America. The listing in his online curriculum vitae reads, “Fellow, Linguistics Society of America, 2007-”. The organization is the Linguistic Society of America, not the Linguistics Society of America. Maybe Pinker gave his c.v. to the secretary to type up, and didn’t have time to proof-read every word. But on page 6 of the P.S.TM section of the 2007 paperback reprint of *The Language Instinct*, he tells us that he received, among other things, “prizes from the Linguistics Society of America ...”, repeating the same mistake. Even his “Responses to the letter to the Linguistics Society of America seeking

revocation of my Fellow status” (<https://stevenpinker.com/lisa-letter>) repeats the insult. It is hard to believe that Pinker gives a damn about the Linguistic Society of America, or language, or science, or anything except his job description and his bank account. Whatever the LSA’s reason for giving Pinker an award, *The Language Instinct*, and my science, were at the center of it.

An Intolerable Law

As a law in physics supplying, as a corollary, the solution to the mystery of the gene-language analogy, the particulate principle is intolerable to anyone whose life is invested in the biology and evolution of language. Part of the ease with which people misinterpret it, and with which Pinker was able to steal it, is that the particulate principle is simultaneously too ambitious and too simple. It answers a question that should not be asked –what makes new or emergent properties possible? I didn’t know the question until after I had the answer. And the particulate principle is too simple. People expect, even demand, to be dazzled by discoveries in science, and are too ready to tell themselves, *Discreteness? Sure. I know what that is.* One commenter wrote, “Abler was so impressed with the discreteness property of the phoneme that he gave it a new name, the particulate principle.” The value of the particulate principle can be judged by the lengths to which Pinker, and others, have gone to to steal it –or annihilate it and its author– and the success that has greeted their efforts. All disproofs of the particulate principle have been dishonest, and have carried a certain burden of risk. But Pinker’s successful plagiarism has gone all over the scientific world, and carried Pinker with it. The particulate principle, in mutilated form, has been his magic carpet. Even Michael Studdert-Kennedy, while acknowledging the role of the particulate principle in governing the atoms in chemical interaction, could not let go of language as a manifestation in biology.

Looking into one’s notes is not a fun exercise. Nevertheless ...

Friday May 27, 1994:

“Steve Pinker’s book is sold out at the U. Of Minn. Bookstore. Try Hungry Mind.”

Saturday May 28, 1994:

“This morning I found the particulate principle of self-diversifying systems in Steve Pinker’s book... My paper on particulation is listed in the bibliography of Steve Pinker’s book but not in the index, and his review of the paper (on page 85) presents the theory of particulation as if it were his own. ... Why was I so scrupulously and thoroughly honest in finding and describing my intellectual antecedents? All I succeeded in doing was providing excuses for dishonesty. I should have hidden them ... It is strong and possibly beneficial tonic to be reminded from high places that one is as nothing in the eyes of the great.”

I sent three letters to Professor Pinker. I should have sent copies to his publisher and chairman, but I was terrified, and not as savvy a politician as Pinker. One of them reads, in part,

November 9, 1994

“I am concerned that I might seem to have stolen my own theory ... Indeed to the extent that my 1989 paper claims to be original (which it does), and to the extent that your (1994) pages 84-85 are taken seriously, I have already been accused of cobbling together a career by raiding the more obscure literature of the last century. If I do not write to you, I may seem to be contributing to the erroneous idea that the particulate principle has been common knowledge since 1836 ...

If there is any truth to the claim of deep humanity made on the last page of your book [*TLI* page 430: “The X-ray vision of the molecular geneticist reveals the unity of our species. ... And so does the X-ray vision of the cognitive scientist. ... no speech seems foreign to me, even when I cannot understand a word ... the motions of a sign language interpreter, the prattle of little girls on a Tokyo playground – I imagine seeing through the rhythms to the structures underneath, and sense that we all have the same minds.”] you will act quickly to correct the terrible situation you have created.”

If three letters a quarter-century ago are harassment by modern standards, then Pinker should have called me out –and he didn’t because he knew I was right. And who is protected under the law? Anyway, I had to stop him, and a few letters was all that I had. As it is, I am still discovering some of Pinker’s tricks, 25 years later.

Another notebook entry reads,

Tuesday June 7, 1994:

“After all, students cheat on exams – why shouldn’t professors cheat on books? The best cheaters would simply travel farthest.”

How to Judge Importance in Science?

Is the particulate principle important? Did Pinker just copy something that gave him an excuse to write a book? Or does the particulate principle somehow run deep in the foundations of science? Pinker’s theft isn’t unique. Three other, well-informed, determined critics have also attacked it. Taken together, the four attacks were sophisticated, independent, vicious, and dishonest. All were different, but the common thread is the will to annihilate the particulate principle and its author, in preservation of the theory in biology. If the reviewers could have found an honest way to disprove the particulate principle, they would have used it. But failing that, they resorted to sarcasm and some of the most amazing misrepresentation of published ideas and basic science that can be imagined. As a law in physics, the particulate principle is intolerable to anyone who has hitched their hopes to the star of the biological foundations of language. The vitriol that the particulate principle, and I, have generated in the highest public forums in science, in an astonishing variety and ingenuity of forms, would not happen if the particulate principle, in its complete form, were not fatal to the biological theory of language.

On the last day of 2005, my book *Structure of Matter, Structure of Mind* was published; and on Saturday, December 22, 2007, I received an unsigned letter postmarked Denmark, with a woman’s name, typed, at the bottom.

The unsigned letter is followed by the name of the supposed author, but never verified by a signature, and so, in doubt. I could not find the supposed author's name listed as faculty or graduate student at the University claimed in the review. I couldn't be sure that a false name hadn't been used, to make its owner look bad, or only to hide the identity of the real owner. Worse, the name could have been genuine, but, without a signature, was a trap, where the author could deny having written the review. We too easily assume that everyone is sincerely doing their best to be clear and to do right.

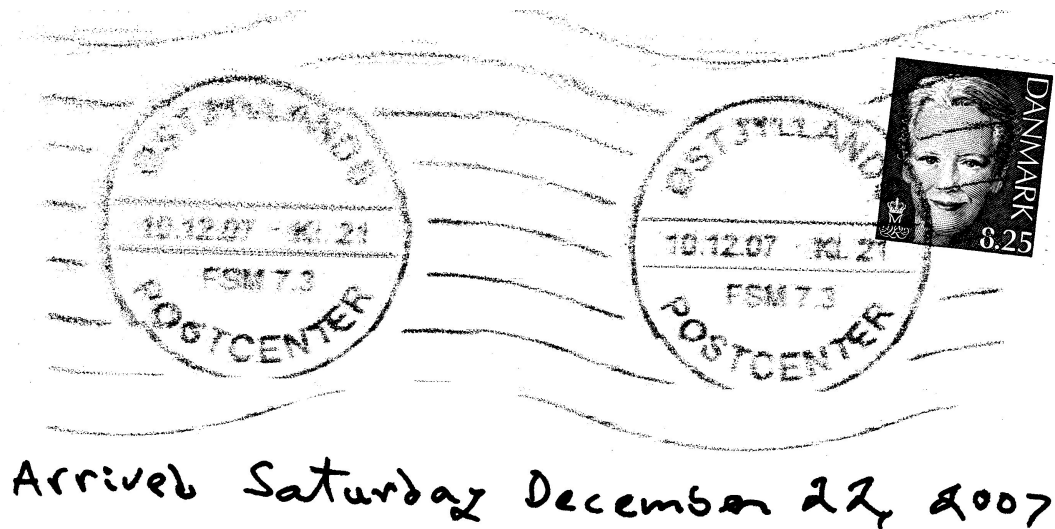

Dear Dr. Abler,

Please find enclosed a courtesy copy of my book notice for Structure of Matter, Structure of Mind. It will be published on the eLanguage website (affiliated with Language, the journal of the Linguistic Society of America) in early 2008.

Sincerely,

(book notice)

Structure of Matter, Structure of Mind: Man's Place in Nature, Reconsidered. William L. Abler.
Sofia, Bulgaria: Pensoft Publishers, 2005. pp. xi, 221. ISBN 978-1891696190, \$49.95.

Any book which claims to make great, sweeping paradigmatic changes to the way we view something as fundamental to our existence as human language, but is written by someone who has not been doing linguistics since his doctoral degree, immediately sets off warning bells in my mind. It was with this skepticism firmly engaged that I read the book. The blurb promises to deliver "a complete, clear, unified theory of the foundations of mathematics, language, and the human mind"; however, nary a mathematician, linguist, nor cognitive scientist was to be found on the jacket quotes. Abler is a staff researcher at the Field Museum in Chicago, where his key area of research has been elucidating dinosaur behavior based on their fossilized teeth; a fine area of inquiry to be sure, but certainly far from linguistics, mathematics, cognitive science, or even philosophy.

The book consists of four extremely unbalanced chapters whose structure is difficult to divine from the table of contents: "Introduction" (18 pgs.), "Character of the Mind" (126 pgs.), "Dialog" (45 pgs.) and "The Pattern Playback, Perception of the Speech Code; A Speech Synthesizer" (3 pgs.). The second chapter consists of many sub-sections, the following of which are bolded in the table of contents, and are therefore, presumably, the key points: The Non-Arbitrariness of Mathematics, Language and Mathematics Compared, The Infinitude of Language. Sets and Symbols, Blending Systems, A Genealogy of Properties, The Human Mind, The Animal Mind. The Emergence of the Human Mind and Culture, Human Logic, Logic versus Experiment in Mathematics, Lessons from History, and A possible Mechanism. The third chapter, whose full title is "Dialog between a Skeptical Reader and the medieval philosopher

Gugliemus Peritior”, is formatted much as one might guess from the title. Gugliemus appears to be the Latin version of the name William, while Peritior is a derivative of a word meaning “experience, skill”, akin to “Abler”; apparently this character is the author’s medieval alter ego.

The last chapter is a strange excursus into the details of a speech synthesizer called “the Pattern Playback”. The author was apparently much impressed by it during a visit to the Haskins Laboratories in the 1970s, considers it to be a “national treasure”, and is much distressed by the fact that the Smithsonian Institution fails to see its relevance and add the device to its collection. The author’s last paragraph, indicative of the timbre throughout his work, reads as follows:

With that last example of understanding a thing by comparing it to something else, I pray the Smithsonian to accept the Pattern Playback, and the reader to accept The Numberline Theory of arithmetic, language, and the universal human mind (2005:196).

Although the references include works by Derek Bickerton, Noam Chomsky, and Steven Pinker, as well as some of the EvoLang conference proceedings, most of his primary literature comes solely from *Science* or *Nature*. It also notably fails to include any of the recent important books on mathematical cognition and its relationship to language, such as James R. Hurford’s *Language and Number*, George Lakoff and Rafael Nuñez’s *Where Mathematics Comes From*, Brian Butterworth’s *What Counts*, or Stanislas Dehaene’s *The Number Sense*.

The key hypothesis (which, due to WA’s meandering and obfuscated writing style, is difficult to distinguish from the hypotheses he claims to refute) claims that equations are a type of sentence, and since (many) equations arise from the fundamental laws of the universe, therefore language does as well. Despite mathematics being at the core of his arguments, he makes several grievous errors, including quoting the fundamental laws of algebra incorrectly and misunderstanding the natural logarithm. The deductions he makes from this flawed base are supported not by reasoning and experiments, but by selected anecdotes, curiosities, listings of

similarities, appeals to common sense, and quotes from famous people. Rather than building a solid support for his main argument, he draws in an amalgam of other fields, each only understood at the level found in popular science literature. The result is a confusing mish-mash of already-disproven ideas, speculations, and irrelevant material. Even if the claims he makes were correct – and most aren't – his bewildering argumentative structure undermines any hope of convincing the reader.

The motivation behind Abler's authorship of this work seems to be his dissatisfaction with the humbling process humanity has undergone during the transition from religious to scientific thought; no longer are we 'made in God's image', but 'modified monkey'. The author professes that evolutionary psychology is the worst thing to happen to science in centuries, and that he aims to restore man to his 'rightful place' in the universe, presumably as more god-like than animalistic, thanks to our connection, via language, with the fundamental laws of the universe. This book is classic pseudoscience, poorly written to boot, and is worth neither the reader's time nor their money.

In spite of its spirited rejection of my book, the review isn't "negative" in any sense that might have been contemplated by the Editor. Without quotes, the reader just has to take the reviewer's word for it. The word "unbalanced" at the top of the second paragraph is vicious and unjustified. A real review might have looked more like this:

Abler claims (page 1) that "due to its spectral composition, light from the star Procion causes evolution". Actually, variation and selection causes evolution. Abler claims (page 2) that "epitaphs and graffiti dating from the Cretaceous period show that at least some dinosaurs possessed language". Actually, no such inscriptions are known. Abler further claims (page 3) that "my cat memorizes one definition out of the O.E.D. every day". Actually, cats are not known to do that. Thus we see that Abler's book is not based on any accepted knowledge.

But the review is not like that at all. It undermines my grasp of mathematics by claiming my "quoting the fundamental laws of algebra incorrectly and misunderstanding the natural logarithm". On my page 28, I show that the prime numbers, and the sides of a right triangle, are the same in any numerical base; and on pages 37-38, I show that language follows the Associative, Commutative, and Distributive laws, as follows:

Associative:

Where $a+b$ is the same as $b+a$,
 [John saw] Bob and Jim is the same as
 [John saw] Jim and Bob.

Commutative:

Where $(a+b) + (c+d)$ is the same as $(d+c) + (b+a)$,
 [John saw] Tom and Carl and Pete and Bob is the same as
 [John saw] Bob and Pete and Carl and Tom.

Distributive:

Where $m(a+b)$ is the same as $ma+mb$,
 [John saw] Tom and Carl is the same as [John saw Tom] and [John saw Carl].

As far as the natural logarithm is concerned, what I really said (page 69) was, "Like a logarithm with its characteristic (its power of ten) and its mantissa (the left-overs)...". Where I don't make a mistake, the reviewer invents one for me. And it is Pinker, not me, who lards his book with quotes from famous people.

By Intuition

And it is true that my basic argument is this: Since equations are sentences, (not "since (many) equations arise from the fundamental laws of the universe") and since algebra doesn't evolve in natural selection, language didn't evolve in natural selection. The idea is much refined since 2005, but if the reviewer could extract it from

my book, the writing is clear enough. And the idea that mathematics is at the core of my arguments is misleading. I am not using mathematics in the way that a mathematician or physicist might use it –to discover new equations or mathematical relationships. I am examining the equation as an object of analysis in itself, and am not concerned with what mathematicians do. Once, when I showed a mathematician that $2+3 \times 4$ is ambiguous, in other words, it could be interpreted $(2+3) \times 4 = 20$, or as $2+(3 \times 4) = 14$, he got mad at me and snapped, “No mathematician would do that!” The precedence of multiplication over addition is a convention adopted by mathematicians to simplify their work, but I am not concerned with what mathematicians do. I am concerned with the structure of nature. Arithmetic is intrinsically ambiguous, and nature is intrinsically ambiguous, and we will just have to live with that.

Yes, I neglected Lakoff and most of the other mathematicians. But my purpose has never been to write what Francis Bacon warned against –books about books. My purpose has been to write books about nature. I have addressed some of the books in my 2019 Quantum-Newtonian theory of language in *JIS Journal of Interdisciplinary Sciences* 3(1):56-77. Available for free by Googling <abler quantum words>. Here is what I was thinking in 2005: I saw that George Lakoff had recruited a mathematician as collaborator (Lakoff & Rafael Núñez 2000. *Where Mathematics Comes From*. Basic Books), so he would be giving lessons in higher mathematics, when it is the structure of lower mathematics that cries out to be understood: If you can’t understand the structure of $a=b$, it is pointless to look at $a^2+b^2=c^2$ in the same way that mathematicians have been looking at it since the days of Pythagoras. I could not help remembering Vladimir Nabokov’s story of appointing an elephant to the faculty of your Zoology Department: An elephant is a terrific example of zoology, but not necessarily the best zoologist. By intuition, I couldn’t spend the time to master what I knew was a conventional look at mathematics. And now that I have taken the time, I see that I was right.

And if I were dissatisfied with the humbling experience of being a modified monkey, a phrase lifted from Huxley, I would not have spent all those years studying honey bees and dinosaurs. And my doctorate not only is in linguistics, it is from the same Department where Chomsky got his doctorate –Penn.

The book review says, “most of his primary literature comes solely from *Science* or *Nature*”, an insult meant to show that, in my laziness, I have used only what is easily available. This old trick is as effective as it is ridiculous: Make a statement, whether true or not, and let the reader jump to the conclusion that it is fatal. Actually, out of 181 references in *Structure of Matter*, I have eight references in *Science*, and nine in *Nature*. If that is fatal, well, amen. But the book includes some bibliography stories that are abridged, and I will take the opportunity to tell them more fully here.

Original Reference

The most famous picture of the honey bee brain is the drawing by Santiago de Ramon y Cajal, which can be seen, duplicated in Figure 94 D, on page 257 of Robert Snodgrass *Anatomy of the Honey Bee* (1956. Ithaca: Comstock). But the second-

most-famous drawing of the honey bee brain is in a study of fiber tracts, by Hieronym Jawlowski. Bullock-and-Horridge's enormous *Structure and Function in the Nervous System of Invertebrates* (1965. San Francisco: Freeman) gives a reference for Jawlowski 1958, but when I decided that it would be a thrill to be in the presence of the original, I found that it wasn't where Bullock and Horridge said it was. I spent three days combing through Grzimek, a listing of zoological references, until I stumbled upon the right reference:

Jawlowski, Hieronym 1957. Nerve tracts in bee (*Apis mellifera*) running from the sight and antennal organs to the brain. *Annales Universitatis Marie Curie-Sklodowska* (D). 12(22):307-323.

The journal was listed in a Medical Library downtown, but you had to be affiliated to get in. I forget how I did it, probably by waiting in the card-catalog section until they moved the check-in station from the central desk to the outer door, but I found a way to sneak into the Library, and, at last, found Jawlowski in a recessed cubbyhole lined with journals. I visited him several times, basking in Jawlowski's presence, and in finding the right reference, which I published in my 2005 book. You can watch the Bullock-and-Horridge bum reference stagger through the literature.

I have another bibliography story from 2005. In his 1930 *Genetical Theory of Natural Selection*, Ronald A. Fisher refers to German physiologist August Weismann's minor theory of mutational momentum, but never mentions what Weismann calls "ids", what we now call genes. It was impossible to believe that Fisher didn't know Weismann's concept, so, driven by anger, I visited the Northwestern University Math Library in Evanston, just north of Chicago, to catch Fisher hiding Weimann's theory. I went early in the morning to give myself plenty of time. I knew that the Library held most of J.H. Bennett's 1971 *Collected Papers of R.A. Fisher* (South Australia University of Adelaide. 5 volumes), an enormous encyclopedia that occupies at least two feet of shelf space. Luckily, the Library collection held the volumes through 1930, so I started looking. From the style of the papers, it was obvious that Fisher was never going to mention the ids, and I began to wander through the pages. Eventually I found a list of minor publications, not reprinted in the *Collected Papers*, and among them, a book review.

Fisher, Ronald A. 1926 (July). The theory of the gene. *Science Progress* XXI(81): 159-160. A review of Morgan, Thomas Hunt 1926. *The Theory of the Gene*. New Haven: Yale University Press xvi+343 pages.

Here was Fisher's mistake. By writing a book review, Fisher was ceding the initiative to the book's author. Bennett's *Collected Papers* listed the journal as *Sci. Prog.*, which I interpreted as *Scientific Progress*. The Librarian told me that there is no *Scientific Progress*, but there is a *Science Progress* –would I like to see it? Would!! He led me down to a concrete basement below the basement, to a vast chamber maybe two blocks long, lined with "compactor" book-cases that roll on railroad tracks, to maximize the use of storage space. The book-cases are packed one against the next,

but by rolling the book-cases along, you can open up a single aisle where your book lies buried. I squeezed into the narrow opening between the bookshelves. There it was. *Science Progress* 1926. Fisher writes: "In chapter ii, in particulate theories of heredity, Professor Morgan touches on Darwin's gemmules, and Weismann's ids." I had him.

Another time, my biology teacher, in 1962, taught us that "Continental drift is an example of a crazy idea in science", and that the word "Gondwanaland" [shown in the map on page 85 of Alfred Wegener's book] "was cooked up by the geologists to make fun of continental drift". (Alfred Wegener, the same one who showed the buoyancy of the mountains, was the best-known advocate of the theory of continental drift. The definitive edition of his *The Origin of Continents and Oceans* was published in 1929; and Wegener died in Greenland the following year. We know that, at that time, about half of responsible geologists accepted continental drift theory, because Wegener conducted surveys at geology conferences. Two decades later, in 1950, probably no responsible geologists accepted the theory.) And I remember, some years later, being taught by a historian of science seated in his office "You know why no one accepted the theory of continental drift? Because Wegener failed to suggest a mechanism that might move the continents around." I went to the bookstore and found a Dover copy of Wegener's book in the "used" section, and told myself, "OK. Now I will watch Alfred Wegener fail to suggest a mechanism that might move the continents around."

I hardly need mention that Wegener's page 58 reads, in part, "all authors who support the idea of a molten layer tend towards the view that the viscosity of this layer is low enough to permit large displacements, convection currents in fact ... below the continental blocks excess heat is generated by radioactivity and that therefore the temperature is continuously rising; this reaches the point where melting occurs and the blocks are floated. They then move over cooler portions of the globe which were formerly ocean regions". Wegener quotes geologist Daly: "A conceivable explanation may be found in the comparatively recent sliding of North America over the sunken crust of the old, Greater-Pacific basin". Wegener adds, page 178, "several authors ... have made use of the concept of convection currents in the sima" [silicon-magnesium rocks that form the ocean floor]. You can't double-check everything, but where critical ideas are at stake, the effort pays with dividends. The myth that "Wegener never suggested a mechanism that might move the continents around" is still alive and well in the scientific gossip. The flaw isn't Wegener. It's us. We will do anything, even lie to ourselves for a hundred years, to ensure that the face looking back at us from the mirror reflects someone who knows what they are doing.

My late friend, the historian Paul Barrett, once told me that, "If history has one lesson, it is that people will think what they want, no matter what". To this I might add Upton Sinclair's warning, often quoted in relation to climate-change, "It is difficult to get a man to understand something when his salary depends upon his not understanding it".

The Snowflake Theory of Language and Mind

The talking machine was a true controlled experiment. Mostly, where language is concerned, science goes out the window. I made the spectrograms. Together with my experiments into the cutting power of smooth and serrated teeth, and my studies of the brain of honeybees for which I designed and built specialized instruments, a bee stereotaxic device with bearing surfaces made from squares of microscope cover-glass, and (Abler, William L. 1977. A restrainer for honey bee head surgery: a bee anesthetic: and a 'lock' for restoring bees to the hive. *Annals of the Entomological Society of America* 70(5):660-662). I will bet that I have done more experiments – controlled physical experiments, not psychological statistics experiments– than the reviewer. Any experiment is preceded by thinking, and no experiment is free from theory. You have to know when to think and when to act; and the quantum-newtonian theory is the only one that yields a clear hypothesis for the mechanism that generates the sentence –a water crystal somewhere in the structure of brain cells. And that can be tested, under the name “the snowflake theory of language and mind”. The quantum-newtonian theory is also the only one that offers any explanation for Wigner’s 1960 “unreasonable effectiveness of mathematics in the natural sciences” –the origin in symmetry and equal-and-opposite, of the mechanism that generates equations. A clear hypothesis for two critical mysteries in science isn’t bad. If the evolution-of-language enthusiasts would do more thinking and less experimenting, they might learn something. As it is, the science of language evolution is like Tom Lehrer’s Song of the Chemical Elements: it shows how much you can know without understanding anything. My research grew more and more abstract as it developed. In the end, it yielded the most concrete, testable hypothesis available for the mechanism that defines and generates the sentence, and the bridge that joins mathematics to physics.

Real Mistakes and Fake Ones

My studies of honey bees and dinosaurs were originally directed at the idea of convergence between human beings and some other animal. I can’t help it if nature doesn’t take all of our suggestions, even if sentences *are* generated by the same mechanism that generates equations. I don’t remember saying anything about us being made in God’s image, or trying to restore us to our rightful place in the universe. Oh, well. If I had made real mistakes, the reviewer would have had no trouble exposing them and disproving my theory, and wouldn’t have resorted to ridicule and made-up mistakes and psychoanalysis to disprove my book. Sometimes I feel like I am being pelted to death with red-herrings. These bogus attacks, combined with Pinker’s plagiarism and deliberate omission of the preservation of atoms in chemical interactions, are the last gasps of a dying theory.

In spite of the dishonest nature of the book-review, its author was the first to write out the consequences of the particulate principle –“great, sweeping paradigmatic changes in the way we view something as fundamental to our existence as human language”.

Style

Ordinarily, I wouldn't say anything about an author's scientific writing style, since style is not "substantive", in other words it deals in persuasion rather than facts and logic. But as a dying science becomes less and less tenable, its defenders appeal more and more to style to defend it. In the same way that no fact is free from theory, no text is free of style. The author of the above book review adopted an in-your-face bombastic style, a kind of rhetorical Don't-Tread-On-Me. Theophrastus Bombastus von Hohenheim. Pinker befriends you with his folksy pose, especially visible in his reply (page 8 in the P.S.TM to the 2007 paperback reprint of *TLI*) to the Frequently Asked Question, "Did you ever study or work with Noam Chomsky?" "No", answers Pinker, "we were in different departments, and given how universities work, our paths didn't cross much from day to day." Dear Steve, another working stiff just like you. Trying to get along.

In the University

Nonsense (euphemism). I was an assistant professor at a midwestern university for six years (until they dissolved their Linguistics Department), and had no trouble connecting with other Departments. The Chemistry Department gave me lab space, and let me keep my bees in a third-floor window of the Chemistry Building. I used a cigar for a bee-smoker. You could still smoke in academic buildings in those days. I did my histology and microscopy in the Psychology Department histology lab, and still have some hundred thin-section brain-slices that I made from honey bees, bumblebees, and solitary bees. I made paraffin and nitrocellulose sections. Some of the Biology faculty gave me silver Protargol and osmium solution and gold chloride, as staining agents for nerve cells. Gold chloride. Imagine it. The color is a glory to see. The result is quite striking. I was the outside reader on most of the dissertations in Psychology because I knew the science but was not in the Department. I was a friend of a faculty member in Design, and presented a lecture titled "As Others See It", on insect vision, for a symposium that he organized as part of an art convention in New Orleans. And when one of the Biology faculty accidentally cracked an expensive glass filter tube, he turned to the Linguistics Department for relief. Who else? I asked him to give me an assistant and some lab space, and not to count on anything.

The crack was visible as a thin, silvery river in the side of the glass cylinder. The assistant and I played gas torches over the glass until the whole device was heated up. I didn't want local expansion to cause the crack to grow. Then I concentrated my flame against one end of the crack, slowly moving along it. You could watch the silver river become shorter and shorter as the crack healed and sealed. Finally, it was gone. Pinker is either showing his lack of imagination, or has found a cute way to present himself as just a regular guy. Any difficulty in communication between the Departments of a university reflects the personality of the people, not the structure of the university. All you have to do is look them in the eye and start talking.

The matter of personality runs deep, and is the reason why the best ideas never come out of the university. They come from highly trained, highly motivated outsiders who make their discoveries alone as a labor of love. Because they can. History has many uses, and one of them is to entertain ourselves with tales of the priest who

argued for the heliocentric theory of the universe (Copernicus, who was a skilled mathematician); the refugee from the plague in London who introduced the beginnings of the calculus and universal gravitation (Newton, a student at Oxford, isolated in his mother's garden because of the plague); the doctor of medicine who invented the controlled experiment (Francesco Redi) and disproved spontaneous generation; the foreman of cannon production who disproved the phlogiston, or fluid theory of heat (Benjamin Thompson, Count Rumford, who invented what we know as the "Franklin" stove); the printer who showed the nature of electricity, introduced the first control of a natural disaster, and set the stage for Coulomb (Franklin, who chose a topic that would let him get up-to-speed quickly); the tutor in English and "the Mathematics and ... Universal Grammar" who published his *Elements of English Grammar* in 1801, and introduced the modern concept of the atom (Dalton, whose school library included Newton's *Principia*); the man trained only as a country vicar who introduced the theory of natural selection (Darwin, lifelong student of natural history, and author of *The Voyage of the Beagle*, and three volumes on the anatomy of barnacles); the monk who introduced the modern concept of genetics (Mendel, the natural-born mathematician who studied physics under Doppler of the Doppler effect); the patent-office clerk who introduced the theory of relativity (Einstein, who held a doctorate in physics from the University of Zürich). Why can't we put two-and-two together? Training, motivation and isolation are the keys. The only really great discovery to come out of the university was that of the periodic property of the chemical elements, by the eccentric professor of general chemistry at St. Petersburg University, Dmitrii Mendeleev, 1869, who was so captivated by a teenage artist, that he and his wife divorced, and, when the teenager's father sent her to Rome to get her away from Mendeleev, he followed her there and proposed (page 138 in: Gordin, M.D. 2004. *A Well-Ordered Thing*. New York: Basic Books). The university is much more a forum for the discussion of ideas than a crucible for generating them.

I once read some advice from a scientist who had been a grants officer for several decades, and had a keen sense for what gets funded, and what doesn't. He advised his readers to make themselves part of the community by applying for grants, and, after giving the obvious advice, "weed out all mis-spellings and punctuation faults", his first substantial advice was, "Lower your sights". And a very highly-placed scientist advised me, in writing, while I was working on what became my 2005 book, "Don't say anything that anyone is liable to disagree with". I have known scientists who succeed by deliberately avoiding anything out the mainstream. I have been told twice, once in conversation by a medical student, and again in writing by a very highly placed scientist, "The only reason you have anything to do with ordinary people is to give yourself someone to feel better than." The quotes are close enough, and if this is the formula for success, it is no wonder that the best ideas never come out of the University.

On page 1 of his *History of Free Fall*, Stillman Drake (Two New Sciences. 1989. Toronto: Wall & Emerson) observes, "Discovery of the law [of fall] by [experimental] means would be easier from rough measurements than from painstaking ones." In some measure, this is why a determined, prepared amateur make nearly all the basic discoveries. The outsider looking in knows enough of the subject to see its outline,

instead of trying to solve limited problems. Just enough physics, just enough math, just enough biology, just enough philosophy. They have time to sift through the ideas without having to justify themselves to critical colleagues every day. And they don't try to solve old problems posed in old language, but simply accept their results as they find them.

Language in Science and the World

There are powerful reasons for the lack of ideas in the university, beginning with the personality features that keep the faculty members in line. Some University people don't want to get out-of-synch with their colleagues, and so express ideas designed more to please than to probe. Other university people can deliver the line "It is not!" or "Well, obviously!" or "It doesn't count!", or "It's been done!", or "It was known!" with such palpable authority and finality that it would win an Academy Award if delivered on-screen. An editor to whom I sent a manuscript about the particulate principle once told me, "It's too much about *language*. My husband is more liberal than I am, and even *he* agrees." You could hear the loathing drip from her lips as she mouthed the word "*language*". A certain university professor who I know marches gallantly along, arms swinging in time to the step, face lifted to the sky, announcing with a triumphant grin "Plagiarize away! Just so the ideas get out there!", eyes flashing with victory. But the ideas don't "get out there". Plagiarists are people, too. They have their needs. And if it doesn't fit the science, too bad for the science. After a while, the safety of tenure gives people the impression that they somehow deserve tenure, and that "I'm OK; everything's OK". You can get a prestigious Government grant for some focussed project like "Development and Neural Bases of Words and Rules," or "Language Learnability and Language Development", as Steven Pinker did, but you can't get one for being convinced that the scientific study of language is going nowhere, and promising to re-think the concept of language. The particulate principle, not to mention the equal-and-opposite theory of the sentence, could never have been discovered in a university.

History has other uses, too –particularly its ability, once a thing is known, to find "the 'anticipations' which are so easy to discover in the past – things which often owe a little, no doubt, to the trick-mirrors of the historian" (page 22 in Herbert Butterfield's 1957 *The Origins of Modern Science*. New York: The Free Press). Butterfield's "trick mirrors" may be placed deliberately, to push the appearance of a discovery back before the actual discovery, and rob the discoverer, the way Pinker did, by using the familiar mystery of the gene-language analogy to make its solution seem familiar. Or an author may use them just to make him/herself look wise. So, Gennaro Auletta notwithstanding (2011 *Cognitive Biology*. Oxford University Press, page 58), Wilhelm von Humboldt's (1836 *Linguistic Variability*, page 70) "infinite use of finite media" isn't the particulate principle; and Humboldt didn't introduce the concept of discreteness into what Robert Hutchins called "The Great Conversation" (Chicago: University of Chicago Press 1952). Humboldt introduced the idea of systems with properties beyond those of their original constituents, but had no idea what the properties of such constituents might be. Auletta (page 7) set out to obtain an "autonomous (i.e., not reducible to physics and chemistry) foundation of biological sciences". Auletta's quest

may represent a valiant effort, but he knew that chemical interaction happened before the origin of life. And Auletta the physicist should have known that nothing in nature happens apart from physics. In the end, his project was at best misguided. Like the evolutionary linguists, he decided the conclusion that he wanted, then set out to gather observations to support it. With his prestigious publications in quantum mechanics, (*Quantum Mechanics* 2009. Cambridge University Press, 755 pages), he might have noticed that the quantum property is a manifestation of the particulate principle. But that would have been an acknowledgment of his pre-biotic nemesis.

Gennaro Auletta ends up by painting himself into a scientific corner: Auletta notwithstanding (ibid, page 58), it is not the case that “the particulate principle ... was first proposed (for explaining biological heredity) by Ronald A. Fisher.” Fisher was intent on showing that the gene is particulate, and, in spite of his very correct “ $1/2(x+y)$ ”, he never applied it outside of genetics, and never had any concept of a universal law of nature. Auletta may be using his cagey “for explaining biological heredity” to explain that he only meant the gene, but the impression is to falsely push back my 1989 theory to Fisher in 1930.

Pinker’s mistreatment of the particulate principle and its author can only be understood against the background of the times. It is part of a minor fad in science. The particulate principle represents a double challenge to anyone who has devoted their life to language evolution. First, the particulate principle represents something that they should have seen, but didn’t. Next, it represents the end of the biology and evolution of language. Only a few abused it deliberately, but they were the leaders. Their comments were immensely influential, and all resorted to the only possibility left to them –dishonesty. The power of the particulate principle can be measured by the absolutely psychedelic contortions of deceit indulged in by top-drawer scientists who simply could not live with it or without it.

Moving the Checkers Around

Pinker provided the model. His pages 84-85 begin with a description of language (the discrete combinatorial system), focussing the reader’s attention on a simple formula, and on language itself. He knew that his readers were willing to accept description in place of theory, so that the theory could be downgraded to the status of an explanation. By leaving out chemical combination and great antiquity, he could avoid the danger posed by a theory in physics. Even Michael Studdert-Kennedy picked up Pinker’s formula, because the theory as-a-whole was too abstract both for his readers and for him. Pinker’s (1994, page 84) “A finite number of discrete elements (in this case, words) are sampled, combined, and permuted to create larger structures (in this case, sentences) with properties that are quite distinct from those of their elements” is neither a description nor a theory of a sentence, but its mark in MSK’s, (1998, page 203) “elements drawn from a finite set (e.g., in spoken language: phonemes, words) are repeatedly permuted and combined to yield larger units (words, sentences) higher in a hierarchy, and more diverse in function than their constituents” is too clear to be missed. MSK is quoting Pinker, not me, and by the time he adds, “The particulate units in chemical compounding include atoms and molecules” ... and an

explanation of Fisher's (1930) reasoning and the particulate principle, the reader's thirst for information about language is already satisfied. (Studdert-Kennedy, M. 1998. The particulate origins of language generativity. Pages 202-221 in Hurford, J., Studdert-Kennedy, M. & Knight, C. (eds.)1998. *Approaches to the Evolution of Language*. Cambridge). The rest is just explanation.

Pinker's page 84 reappears on page 519 of *The Routledge Linguistics Encyclopedia* (New York: Routledge): "a finite set of discrete units can be repeatedly combined in different permutations", adapted from MSK 1998. But *Routledge* read MSK's next paragraph, too, and adds, "Far from being unique to language, the particulate principle (**compositionality**, or Chomsky's **discrete infinity**) is seen throughout the natural sciences, from the genetic code in DNA to chemical compounding" (*Routledge's* bolding). *Routledge* attributes the name "particulate principle" to me, but degrades the concept to Chomsky's descriptive "discrete infinity", and attributes the concept of a connection with atoms and genes to Chomsky –a law in physics of which, even now, Chomsky has no inkling. *Routledge* was just trying to be helpful, but Pinker's degraded concept of the particulate principle has become a kind of public property that applies to the gene and chemical compounding while no one realizes that language is governed under a law in physics.

Style

"Rather different" from Pinker's folksy pose, is Peter MacNeilage's pose of supreme wisdom, under which he bludgeons you with his refinement. I only wish I could copy the Acknowledgments to MacNeilage's 2008 *The Origin of Speech* (Oxford University Press), in which he rubs the reader's face in the honor and esteem with which he is received throughout the scientific world. But that would be plagiarism. I held off from looking too deep into the possibility that someone besides Pinker had plagiarized the particulate principle. I wanted the theory to be fairly complete before launching myself into the chaos of a dispute over plagiarism. The important thing is to solve the mystery all the way through, and to get it right. The example of Alfred Russel Wallace was constantly in my awareness. Wallace discovered natural selection independently from Darwin, and has his own fan club and cheering section, of which I am a member. Wallace lived until 1913 –well into the age of Mendel. But under his slogan, "Natura saltum non facit" –Nature doesn't make jumps– Wallace never accepted Weismann's idea of a particulate gene. I had to keep telling myself, "Don't make Wallace's mistake. Don't stop, don't stop, don't stop. Solve the problem clear through to the end. If you can't get it right, nothing else matters".

I have been called out for wasting time in working out the geometric formula showing that every key on the violin has the same finger-placement pattern (Abler, William L. 2002. Just say, "2-HI, 2-MID, 2-LO": a system for remembering finger placement in various keys on the violin. *American String Teacher* 52(3):56-62). It's funny how something from one world can spill over into another in unexpected and powerful ways. 2-HI, 2-MID, 2-LO was an exercise in thinking a puzzle clear through to the end, spilling over from solving a puzzle in music to solving a puzzle in science.

Probably the formative work of our time also comes from art. *The*

Autobiography of Benvenuto Cellini is not only the model for all autobiography, but Cellini himself (born in Florence, 1500) is the model for the modern Western personality. We all know him from his statue of Perseus Holding the Head of Medusa. We are, all of us, even scientists, children of Benvenuto Cellini. Even the bicycle racers Major Taylor (Todd Balf 2008. *Major*. New York: Three Rivers) the turn-of-the-century black cyclist who made himself the world's fastest racer in a white world, Ottavio Bottecchia (pages 75, 83 in: Geoffrey Wheatcraft 2003. *Le Tour*. London: Pocket Books) the Italian racer who criticized Mussolini and got murdered for his trouble, and Gino Bartali (Aili & Andres McConnon 2012. *Road to Valor*. New York: Crown) the Italian racer who repeatedly, and at total risk to himself, out-smarted the Nazis, and hid a Jewish family in a house that he owned outside Florence during World War II, –and helped to restore a spirit of heroism in peacetime to an exhausted Europe after the War by winning the 1948 Tour de France, offer a model of tenacity and courage that any scientist might emulate. Even evangelist Aimee Semple McPherson (pages 33-34 in: Matthew Sutton 2007. *Aimee Semple McPherson*. Cambridge: Harvard), in spite of her undeniable faults, faced down the Ku Klux Klan in her Four-Square Gospel Tabernacle, in an act of courage to inspire any scientist.

I even told myself that, after Pinker, no one else would plagiarize the particulate principle. Would they? But when I thought that the theory was mature enough, and safely written down, so I couldn't get shaken loose from it, I Googled "chomsky particulate principle". Within a second, at the bottom of Peter Macneilage's page 97, I found, "Chomsky's generative grammar, of course, incorporates the particulate principle." Once again, I felt the hairs stand up on the back of my neck like I was being eaten alive by a mad dog. I had been wrong. Other minds were at work, busily gnawing away at my theory, and at me.