

A representationalist theory of the semantics of *different, the same, and each other*

Shûichi Yatabe
University of Tokyo

June 21, 2021

Abstract

In this article, I present and defend a theory of the internal readings of symmetrical predicates such as *different* and *the same* in which the meaning of such predicates is taken to contain the meaning of a reciprocal pronoun. The theory is shown to be able to account for the truth conditions of sentences in which the antecedent of a symmetrical predicate is a quantificational DP, sentences in which *the same* is used as part of a partitive construction, sentences containing multiple symmetrical predicates, and sentences in which a symmetrical predicate is under the scope of a negation. In addition, I present a novel theory of the semantics of reciprocal pronouns that is capable of assigning adequate truth conditions to sentences in which a right-node-raised reciprocal pronoun is anteceded by more than one DP simultaneously and sentences in which the antecedent of a reciprocal pronoun is a DP headed by a determiner like *most* and *no*. Both these theories are HPSG-based and representationalist, involving constraints on the form of semantic representations and, in the case of the former, even operations that copy and modify parts of semantic representations.

1 Introduction

A sentence like (1) can be interpreted in at least two ways.

- (1) The two students read different books.

First, it can mean something like “The two students read books that were different from the contextually salient book.” This is called the external reading of the sentence, because in this reading the books referred to are compared with some other book that has been mentioned outside the sentence. The sentence above can also mean “The book or books that the first student read and the book or books that the second student read were different from each other.” This is called the internal reading of the sentence, because in this reading the books referred to are compared with some other book or books also mentioned inside the sentence. A sentence like *The two students read the same book* likewise has a reading that could be called its internal reading, in which it means something along the lines of “The book read by the first student and the book read by the second student were identical to each other.”

Let me explicate the meaning of several further terms that I will be using below. *Symmetrical predicates* are expressions like *different* and *same* that are able to give rise to the internal readings of sentences in which they occur. The *antecedent* of a symmetrical predicate is that expression *E* such that the sentence will lose a given

internal reading if E is replaced with another expression whose meaning does not involve any plurality or quantification. For instance, in sentence (1), the expression *the two students* is the antecedent of *different*, and in sentence (2), the expression *every student* is the antecedent of the word.

- (2) Every student read a different book.

It is claimed in Brasoveanu (2011) that an internal reading induced by a symmetrical predicate whose antecedent is a singular and distributive quantifier should be distinguished from an internal reading that is induced by a symmetrical predicate whose antecedent is some other kind of expression. In Brasoveanu's view, internal readings of the former type, exemplified by (2), form a natural class with external readings, while internal readings of the latter type, exemplified by (1), should be considered to be a somewhat separate phenomenon. He claims that the following generalization lends support to this view.

- (3) Implicational universal: if a language has a lexical item that can have sentence-internal readings under singular and distributive quantifiers, then that item can also have sentence-external readings.

(from Brasoveanu (2011))

German is one of the languages that seem to conform to this generalization; for instance, the word *anders* 'different', which can have an internal reading when anteceded by a singular and distributive quantifier, can have an external reading as well, whereas the word *verschieden* 'different', which cannot have an external reading, generally cannot have an internal reading when anteceded by a singular and distributive quantifier (see Beck (2000) and Brasoveanu (2011)). Assuming that the generalization is indeed valid, it seems reasonable to conclude that sentences like (1) and sentences like (2) need to be dealt with by separate grammatical mechanisms, as Brasoveanu suggests.

The central aim of this article is to present an HPSG-based, representationalist theory of the type of internal reading exemplified by sentence (1). The proposed theory is based on the idea that the meaning of a sentence like (1) involves the meaning of a reciprocal pronoun, and in what follows, I will present not only a theory of symmetrical predicates but also a new theory of the semantics of reciprocal pronouns which is arguably an improvement over existing theories.

Throughout the article, most examples will involve symmetrical predicates whose antecedents are plural DPs, as in (1), and I will use the term *internal reading* to refer only to the type of internal reading exemplified by (1), disregarding the type exemplified by (2). Examples of apparent internal readings in which expressions other than DPs or NPs seem to be functioning as antecedents of *different* or *same* will be discussed in the penultimate section of the article.

2 Previous analyses of internal readings

I will first survey the previous literature on the internal readings of *same* and *different* and argue that none of the existing theories capture the full range of relevant facts.

2.1 Partition-based theories

First, let me discuss the theories proposed in Beck (2000), Brasoveanu (2011), Char-navel (2015), and Kubota and Levine (2016). There are important differences between these theories, but I will refer to all these theories as partition-based theories because

they are all based on the view that a DP containing a symmetrical predicate and the antecedent of a symmetrical predicate both denote some sort of group that can be partitioned.

To illustrate the claim embodied in this family of theories, I will use the following example.

- (4) The students saw different films.

According to these theories, the internal reading of this sentence says something like the following.

- (5) The students under discussion can be divided into a certain number of partitions, say Partition $S_1, \dots, \text{Partition } S_n$, and there are films that can be divided into the same number of partitions, say Partition $F_1, \dots, \text{Partition } F_n$, such that (i) for each i such that $1 \leq i \leq n$, the student(s) in Partition S_i saw the film(s) in Partition F_i , and (ii) for any i and j such that $i \neq j$, the film(s) in Partition F_i and the film(s) in Partition F_j are different from each other.

In order to achieve such interpretation, internal readings are assimilated to cumulative readings, illustrated by (6), in the theories proposed in Beck (2000), Brasoveanu (2011), and Charnavel (2015), and to *respectively* readings, illustrated by (7), in the theory proposed in Kubota and Levine (2016).

- (6) Two students saw five films.
(7) Chris and Pat saw *Casablanca* and *Shane* respectively.

The cumulative reading of sentence (6) is true if and only if there are two students who each saw one or more films and there are five films that were each seen by one or more students. This reading can be paraphrased as “There are two students, say Student 1 and Student 2, and there are two non-empty sets of films F_1 and F_2 such that Student 1 saw the film(s) in F_1 , Student 2 saw the film(s) in F_2 , and the cardinality of $F_1 \cup F_2$ is five.” It is easy to see that a mechanism that assigns this interpretation to sentence (6) can be employed to assign to sentence (4) the interpretation described in (5). The same can be said about a mechanism that assigns to sentence (7) its only available interpretation.

There are two problems with the partition-based theories of internal readings. The first problem is that there are DPs that can participate in internal readings but not in cumulative readings or *respectively* readings. Consider the following two sentences.

- (8) Most students saw 25 films.
(9) All the students saw 25 films.

As Kamp and Reyle (1993, pp. 328–329) point out about a sentence like (8) and Zweig (2009) points out about sentences like (9) as well as about sentences like (8), sentences like these do not allow cumulative readings; sentence (8) does not have a reading in which it is true if and only if most students saw one or more films and there are 25 films that were each seen by one or more students, and sentence (9) does not have a reading in which it is true if and only if all students saw one or more films and there are 25 films that were each seen by one or more students. At the same time, these sentences obviously do not allow *respectively* readings either. But the following sentences do have internal readings. (The availability of an internal reading in a sentence like (11) is questioned in Brasoveanu (2011) but affirmed in Marsden (2005).)

(10) Most students saw different films. (from Kamp and Reyle (1993, p. 479))

(11) All the students saw different films.

This observation suggests that internal readings should not be assimilated either to cumulative readings or to *respectively* readings.

The second problem with the partition-based theories comes from the fact that, as noted in Yatabe (1988) and Pullum and Huddleston (2002, p. 1144-1145), an adverb like *differently* allows internal readings. Consider the sentence in (12), which can have the same truth conditions as the sentence in (13).

(12) Different people age differently.

(13) Different people age in different ways.

In order to account for sentences like these within a partition-based theory, it is necessary to adopt the hypothesis that both the meaning of the adverb *differently* and the meaning of the PP *in different ways* involve the meaning of a group of “ways” that can be partitioned. Adopting such a hypothesis, however, seems to make it impossible to account for the contrast between the following sentences.

(14) Pat walked differently.

(15) Pat walked in different ways.

Sentence (15) can mean that Pat walked in more than one way, but sentence (14) does not allow such interpretation. This observation gives us another reason to doubt the validity of the view that internal readings are merely interpretations that arise when a given sentence contains two expressions that denote groups.

2.2 The parasitic-scope theory

Let me next discuss the theory proposed in Barker (2007), which I will call the parasitic-scope theory. What is shown in (16) is the denotation that is given to *different* in this theory. The portion of the denotation that says “ $x, y < X$ ” means that x and y are both parts of X . The symbol f is here being used as a variable whose value is required to be a choice function. Ffx and Ffy are supposed to mean $F(f)(x)$ and $F(f)(y)$ respectively.

(16) $\llbracket \text{different} \rrbracket = \lambda F. \lambda X \forall f_{\text{choice}} \forall x, y < X : (Ffx \wedge Ffy) \rightarrow x = y$

There is a transformational grammar version and a categorial grammar version of the theory, which are equivalent to each other. In the transformational grammar version, a symmetrical predicate like *different* is moved out of the DP containing it and takes what Barker calls *parasitic scope* immediately below its antecedent. Thus, when *different* in the sentence *Anna and Bill saw different films* is given an internal reading, the sentence is associated with the LF shown in (17).

(17) $[\text{Anna and Bill} [\text{different}_i [\text{saw} [t_i \text{ films}]]]]$

When this LF is interpreted, the first argument that the denotation of *different* is applied to is the denotation of the VP with an adjectival gap, and the second argument that the denotation of *different* is applied to is the denotation of the grammatical subject, *Anna and Bill*. As a result, the sentence is predicted to mean “Irrespective of which film you pick out, if person x who is either Anna or Bill saw that film and person y who is either Anna or Bill saw that film too, then person x and person y are the same person,”

which is paraphrasable as “Anna and Bill did not see the same film.” This prediction captures at least part of the meaning of the sentence. It is possible to obtain a more complete interpretation by modifying the denotation given to the word *different*.

There are two fundamental problems with the parasitic-scope theory, neither of which can be remedied by merely modifying the denotation given to *different*. The first problem comes from the determiners *most* and *all*, as in the case of the partition-based theories. As the meaning of *different* shown in (16) indicates, the parasitic-scope theory is based on the assumption that the antecedent of a symmetrical adjective, which is the second argument of its denotation, denotes some kind of group, and hence arguably does not work when the antecedent is of the form *most NP* or *all the NP*. DPs headed by *most* or *all* do not denote any kind of group, as shown by the following three considerations. First, recall that DPs headed by *most* or *all* do not allow cumulative readings, unlike DPs like *two students* that clearly denote groups. Second, you cannot say **Most students here each own a car*, as pointed out in Heim *et al.* (1991a). This is unexpected if *most students* can denote a group. And third, in a sentence like (18), the pronoun *they* cannot be interpreted as referring to some majority of the professors (Kamp and Reyle (1993, p. 473)).

- (18) Most professors_{*i*} voted for the same candidate they_{*i*} had interviewed the week before.

In other words, this sentence cannot mean “Some majority of the professors collectively interviewed some candidate, and each of the professors belonging to that majority later voted for him or her.” This is unexpected if the DP *most professors* can denote a group consisting of some majority of the professors.

The second problem with the parasitic-scope theory is that, as pointed out in Kubota and Levine (2016), it is difficult to apply to cases involving two or more symmetrical predicates sharing the same antecedent. Consider the following two sentences.

- (19) At least two counselors told the **same** story to the **same** camper on the **same** day in **different** tents. (from Keenan (1987))
- (20) Different people age **differently** for **different** reasons.

In each sentence, the boldfaced symmetrical predicates share the same antecedent.¹ It is not obvious how to deal with sentences of this type when symmetrical predicates are given denotations like the one shown in (16).

2.3 Polyadic-quantification theories

Finally, let me discuss the theories proposed in Keenan (1987) and Richter (2016), which produce internal readings by allowing a sequence of determiners to form a polyadic quantifier. In this type of theory, a sentence like (21) is associated with a logical form like (22), which Richter (2016) shows could be generated in a straightforward manner if certain assumptions are made about the syntax-semantics interface.

- (21) Anna and Bill read the same books.
- (22) [EVERY, SAME_{*pl*}]({ Anna, Bill }, BOOK, READ)

A logical form like this yields appropriate truth conditions for the sentence when the denotation of a complex determiner like [EVERY, SAME_{*pl*}] is defined as a suitable 3-place predicate that takes two sets and one relation as arguments, as in (23).

¹The first *different* in sentence (20) is not boldfaced because it is arguably not a symmetrical predicate. I will discuss the status of this word in Sect. 7.

- (23) $[\text{EVERY}, \text{SAME}_{pl}](P, Q, R) = 1$ iff there is a set S such that for all $a \in P, Q \cap \{b \in U \mid aRb\} = S$.

Theories of this type avoid the kinds of pitfalls that I have argued are problematic for the partition-based theories and the parasitic-scope theory.

There is, however, a problem involving the internal readings of *same* which may be intractable in the polyadic-quantification theories. The problem concerns sentences like the following, attributed to M. Solomon in Brasoveanu (2011) and Barker and Shan (2014).

- (24) Anna and Bill know some of the same people.

This sentence can mean that there are some people that Anna and Bill both know, but an analysis that uses the polyadic quantifier defined in (23) would assign to this sentence a meaning like “There is a group of people such that Anna knows some of them and Bill also knows some of them,” which does not guarantee that the set of people Anna knows and the set of people Bill knows overlap at all.

An account of sentences like (24) has been proposed both within a partition-based theory and within a parasitic-scope theory. Brasoveanu (2011) uses his version of the partition-based theory to formulate an analysis in which the word *same* in (24) is allowed to be predicated of the variable contributed by *some* rather than that contributed by *people*, giving the sentence an interpretation along the lines of “Anna and Bill know the same subset of the people”. Barker and Shan (2014, Sect. 14.4) present an analysis that they attribute to M. Solomon, in which the word *same* is given a denotation that is capable of turning the phrase *some of the same people* as a whole into a type of expression that takes parasitic scope.

In contrast, there is currently no account of a sentence like (24) that is formulated within a polyadic-quantification theory, and it is not obvious how the issue can be dealt with in this type of theory. One conceivable solution is to regard a string like *some of the same* as an idiom and postulate polyadic quantifiers like [EVERY, SOME-OF-THE-SAME], but such an account is questionable, since the grammatical pattern used in sentence (24) is quite productive. Consider the following attested example.

- (25) CBD and THC have many of the same medical benefits. They can provide relief from several of the same conditions. However, CBD doesn’t cause the euphoric effects that occur with THC.
(<https://www.healthline.com/health/cbd-vs-thc#medical-benefits>)

The first and the second sentence in this example indicate that the head of the partitive construction in this type of sentence does not have to be *some* but can be *many* and *several* as well. An analysis that does not rely on the notion of idiomatization thus seems preferable, and it remains to be seen whether such an analysis can be formulated within one of the polyadic-quantification theories.

3 A theory of the hidden-reciprocal reading of *different*

In this section, I will present a novel, HPSG-based theory of the internal reading of *different*. The theory is based on the idea that *different* in a sentence like (1) has an implicit argument whose meaning involves that of a reciprocal pronoun. The proposed analysis is similar in important respects to what is proposed in Charnavel (2015) as an analysis of *different* in a sentence like (2); this latter analysis is also based on the view that symmetrical predicates have implicit arguments whose content may involve

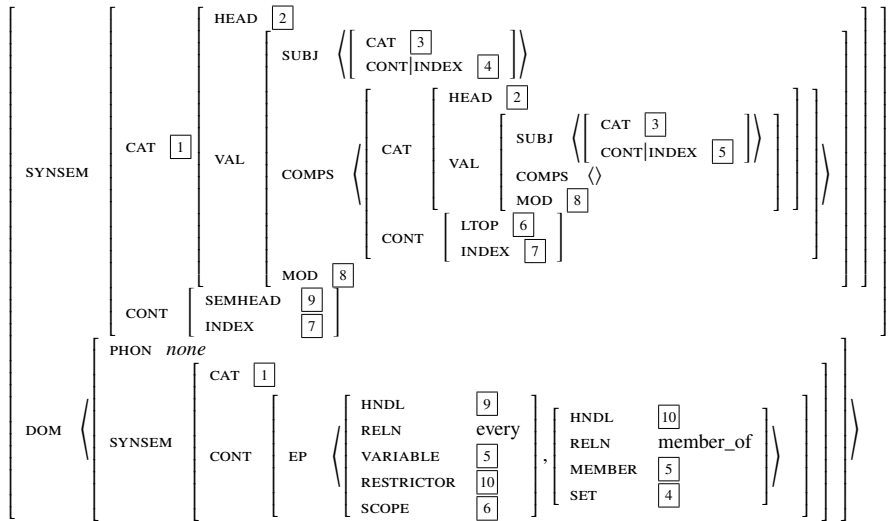

Figure 1: The lexical entry for a silent distributive operator that combines with subject-seeking expressions

that of a reciprocal pronoun. I will argue later in the present section that Charnavel is incorrect in not applying the same analysis to *different* in sentence (1).

The proposed theory is formulated using the modified version of Minimal Recursion Semantics (MRS) that is presented in Yatabe and Tam (2021, Sect. 2). The presentation below presupposes familiarity with that version of MRS. Certain features of this modified version of MRS will be seen to play a crucial role when we deal with examples like (40) and (41) below, which involve right-node raising. However, even in the absence of familiarity with this modified version of MRS, much of what follows will be understandable as long as the reader is familiar with the original version of MRS, presented in Copestake *et al.* (2005). Those readers who are not familiar even with the original version of MRS are asked to consult Sect 2.2 of Yatabe and Tam (2021), which is a short exposition of the basic aspects of the original version of MRS.

3.1 Silent distributive operators

I will start with presenting an account as to how an expression like *the two students* is given distributive interpretation. This is a necessary thing to do because the antecedent of a symmetrical predicate in a sentence like (1) is invariably given distributive interpretation as opposed to collective interpretation, as pointed out in Carlson (1987). The account that I will adopt is one that is based on the assumption that there are two phonologically null distributive operators in the lexicon of English: one that combines with subject-seeking constituents such as VPs and predicative PPs and another one that combines with DPs.

The lexical entry shown in Fig. 1 is the first silent distributor that I propose. It is assumed that an elementary predication whose relation is *member_of*, such as the second elementary predication in the EP list of this lexical entry, is true if and only if the denotation of its MEMBER argument is a member of the set denoted by its SET argument.

I will use an example to illustrate how this lexical item functions. In a sentence like *Three students sang*, this silent distributive operator could be adjoined to the VP, as in (26a), where the symbol *DIST1* is meant to stand for the operator.

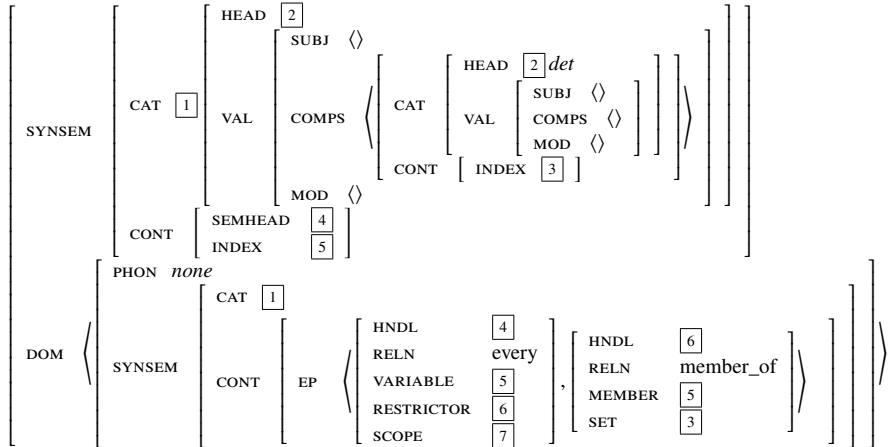

Figure 2: The lexical entry for a silent distributive operator that combines with DPs

- (26) a. $[_S \text{ Three students } [_{VP} \text{ DIST1 } [_{VP} \text{ sang}]]]$
 b. $\text{some}(X, |X| = 3 \wedge \text{students}(X), \text{every}(z, \text{member_of}(z, X), \text{sang}(z)))$

The lexical entry shown in Fig. 1 requires (i) that the complement of the lexical item should be a type of expression that needs to combine with a subject to be saturated, (ii) that the subject of the lexical item should have all the grammatical properties that the unexpressed subject of its complement is expected to have, and (iii) the unexpressed subject of the complement of the lexical item and the subject of the lexical item itself should nevertheless have distinct indices and therefore contribute distinct variables to the semantic representation. In the example in (26a), the silent distributive operator takes as its complement a finite VP, and the constituent made up of the operator and the finite VP thus becomes a finite VP itself, and is duly combined with the subject *three students*. Let us assume that this subject is a DP headed by a phonologically null quantificational determiner whose denotation is roughly the same as that of *some*. Then the sentence (26a) as whole is associated with an MRS representation that is equivalent to the linearly formatted formula shown in (26b), where the argument of the predicate *sang* is z , a variable distinct from the variable contributed by the subject DP, i.e. X . The variable-binding condition, which prohibits a variable bound by a quantifier from being reused either as a free variable or as a variable bound by another quantifier in the same MRS representation, guarantees that the existential quantifier contributed by the subject takes wide scope over the universal quantifier contributed by the silent distributive operator, since the restrictor of the latter contains a variable that is to be bound by the former.

The lexical entry shown in Fig. 2 is the second silent distributive operator that I propose. This second operator is used as in (27), where the symbol `DIST2` is meant to stand for the operator and “(some)” is meant to stand for the phonologically null determiner whose meaning is the same as that of *some*.

- (27) $[_S [_{DP} \text{ (some)}] [_{NP} \text{ three students}]] \text{ DIST2} [_{VP} \text{ sang}]]$

This syntactic structure also gives rise to the interpretation shown in (26b) and no other interpretation, again thanks to the variable-binding condition.

As will become apparent in what follows, postulation of this additional operator is necessitated by sentences like *I questioned them about each other* (Heim et al. (1991a)) and *I gave Anna and Bill different books*, where the antecedents of expressions like

each other and *different* are not grammatical subjects. Postulation of the first silent distributive operator, on the other hand, is necessitated by an example like *men with different names*, discussed in Barker (2007), in which the antecedent of *different* is arguably not an overt DP but the unexpressed subject of the predicative PP, which is coindexed with the preceding plural NP.

3.2 Reciprocal pronouns

Let me next propose an analysis of the semantics of reciprocal pronouns which builds on, and arguably improves on, the theory presented in Heim *et al.* (1991a) and Heim *et al.* (1991b). What is shown in (29) is the semantic representation that is claimed in the proposed theory to be associated with the sentence *Anna and Bill saw each other*, which can have the schematic syntactic structure shown in (28).

(28) [[Anna and Bill] [DIST1 [saw each other]]]

(29) $a = \text{Anna} \wedge b = \text{Bill}$
 $\wedge \text{some}(X, X = \{a, b\},$
 $\text{every}(z, \text{member_of}(z, X), \text{every}(y, \text{other}(y, X, z), \text{saw}(z, y))))$

The existential quantifier in (29), which is expressed by “some” and binds the variable X , is assumed to be introduced into the representation by the mechanism that interprets a conjoined non-quantificational DPs, as proposed in Yatabe and Tam (2021, Appendix D). The predicate *other* is assumed to hold of its three arguments if and only if the denotation of its first argument is a member of the set denoted by its second argument other than the denotation of its third argument. Thus, the subformula “ $\text{other}(y, X, z)$ ” here holds if and only if (the denotation of) y is something in (the denotation of) X other than (the denotation of) z . Given this semantics of the predicate *other*, the representation in (29) as a whole means “Every member of the set {Anna, Bill} saw every other member of that set.”

Shown in Fig. 3 is the lexical entry for *each other* that I propose so that a representation like (29) is produced by the grammar. The *INSTANCE* value, the *SET* value, and the *CONTRAST* value of the second elementary predication in the *EP* list are meant to be the first, the second, and the third argument of the predicate *other*. I assume that the *CONTRAST* value is subject to the syntactic binding condition stated in the following.

- (30) Binding condition on anaphors including reciprocal pronouns:
 An anaphor, such as a reciprocal pronoun, is *non-exempt* when it has a co-argument that is less oblique than it. When an anaphor is non-exempt, one of its less oblique co-arguments must serve as its local syntactic antecedent. An anaphor that does not have a co-argument that is less oblique than it is *exempt*. An exempt anaphor does not have to have a local syntactic antecedent.
- (31) Definition of the term *co-argument*:
 Let s be the *SYNSEM* value of an expression E . Then *synsem* objects that are on the same *ARG-ST* list that s is on are each a *co-argument* of E .
- (32) The constraint on the interpretation of a non-exempt reciprocal pronoun:
 Suppose an elementary predication whose *RELN* value is *other* has been contributed to an *MRS* representation by a non-exempt reciprocal pronoun. Then the *CONTRAST* value of that elementary predication must be identical to the index of the local syntactic antecedent of that reciprocal pronoun.

What (30) says is meant to be a restatement of what is claimed in Pollard and Sag (1994).

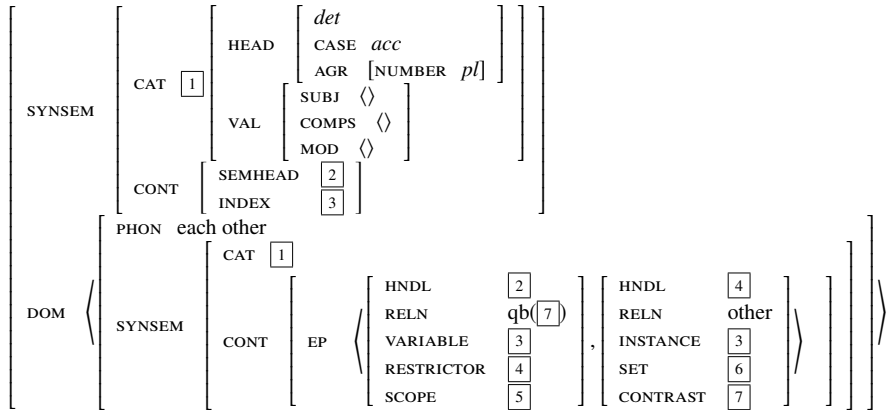

Figure 3: The lexical entry for *each other*

The *qb* function that is used in Fig. 3 to describe the RELN value of the first elementary predication in the EP list is so named because it is a function that maps a variable to the RELN value of the quantifier that binds that variable when there is such a quantifier. The function is defined in (33).

(33) Definition of the *qb* function:

Let x be a variable in an MRS representation R . Then $qb(x)$ is the RELN value of the elementary predication in R whose VARIABLE value is x , if there is such an elementary predication in R . If there is no such elementary predication in R , then $qb(x)$ is *every*.

In the representation in (29), the second occurrence of *every* is what corresponds to the description “ $qb(\overline{7})$ ” in the lexical entry; in this case, $\overline{7}$ denotes the variable z , which is bound by the first occurrence of *every*.

The second and the third argument of the predicate *other* are assumed to be subject to a constraint that specifically applies to the arguments of this predicate; a preliminary version of that constraint is given in (35). The meaning of the expression *to range over*, used in (35), is defined in (34).

(34) Definition of the term *to range over*:

A variable a is said to *range over* a variable b if and only if either a is the same variable as b or a is bound by a quantifier whose restrictor is of the form “ $member_of(a, b)$ ”.

(35) The constraint on the predicate *other* (a preliminary version):

The third argument of the predicate *other* must range over the second argument of that predicate.

The representation in (29) complies with this constraint. In that representation, the third argument of *other*, z , can be said to range over X , which is the second argument of *other*, because z is bound by the first occurrence of *every*, whose restrictor is of the form $member_of(z, X)$.

Unlike the theory presented in Heim *et al.* (1991a) and Heim *et al.* (1991b), the account I am proposing can handle an example like (36), provided that the determiner *most* is associated with the lexical entry shown in Fig. 4.

(36) Most students here know each other. (from Heim *et al.* (1991a))

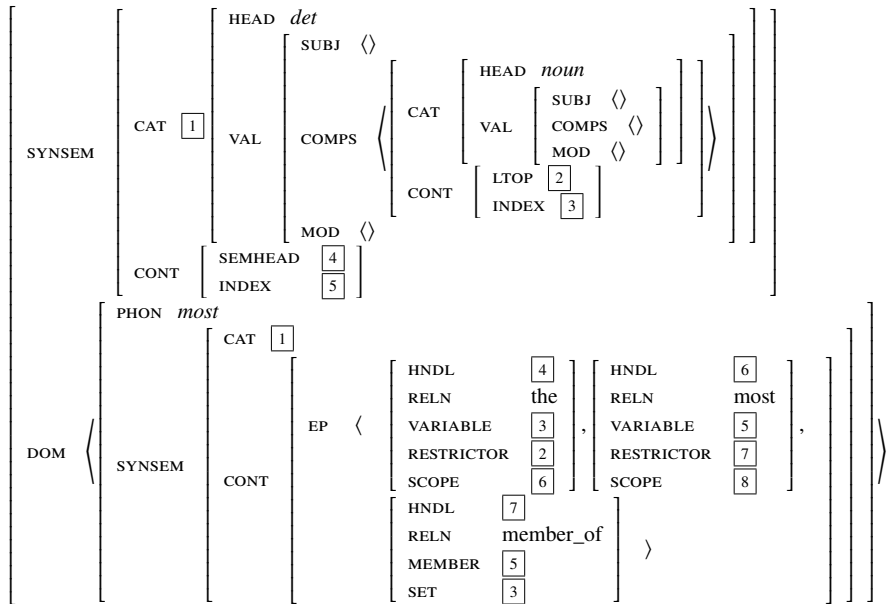

Figure 4: The lexical entry for *most*

Given the lexical entry, the sentence receives a semantic representation like (37), where the *qb* function has duplicated the meaning of the determiner *most*.

$$(37) \text{ the}(X, \text{students}(X) \wedge \text{here}(X), \\ \text{most}(y, \text{member_of}(y, X), \\ \text{most}(z, \text{other}(z, X, y), \\ \text{know}(y, z))))$$

Here and elsewhere, it is assumed that a formula of the form $\text{the}(x, P, Q)$ is true if and only if Q is true when the value of x is the maximal, non-empty set of contextually relevant entities that makes P true. For instance, $\text{the}(Y, \text{men}(Y), \text{visible}(Y))$ is true if and only if the maximal, non-empty set of contextually relevant men is visible. Given this interpretation of *the*, the representation in (37) means “Most of the students here know most of the other students,” which is arguably an adequate description of the truth conditions of sentence (36).

What the proposed theory predicts about the truth conditions of sentence (36) is not entirely consistent with what is said about the truth conditions of sentences like this in Kamp and Reyle (1993) and Haug and Dalrymple (2020). These previous works, however, do not provide a sufficient reason to abandon the theory just proposed. Kamp and Reyle (1993, pp. 468–469) consider the hypothesis that the sentence *Most members of this club know each other* is true iff the set of members a for which there is at least one other member b such that a and b know each other consists of more than half of the members. While examining this hypothesis, they note that the sentence is “arguably true” if the club has 50 members and there is one cluster of five people and seven additional clusters of four people each, such that all and only the people within one and the same cluster know each other. This judgment contradicts the prediction of the theory stated above. I believe, however, that there is a reason to be skeptical of the validity of this line of thinking: the sentence in question seems to be clearly false if the club consists of 25 pairs of people such that each person only knows the other person in the pair that he or she belongs to. In light of this observation, I am

inclined to discount not only the hypothesis under discussion but also the judgment that Kamp and Reyle describe, since it is possible that the latter was partly motivated by the former. More recently, Haug and Dalrymple (2020, Sect. 5) have proposed a theory according to which the sentence *Most members know each other* is:

- a. true if the maximal subset D of members such that everyone in D knows everyone else in D contains a majority of the club members,
- b. false if the set of members who know at least one other member contains less than half of the club members, and
- c. neither otherwise.

Unlike the theory that I proposed above, this theory does not predict that *Most members know each other* is true in a situation where there are five members A, B, C, D, and E, A knows only B, C, and D, B knows only C, D, and E, C knows only D, E, and A, D knows only E, A, and B, and E knows only A, B, and C. In fact, no matter how large n is, it is always possible to envisage a situation where each of the n members know $n - 2$ other members and where Haug and Dalrymple’s theory nevertheless does not predict that *Most members know each other* is true. I believe this is a shortcoming of their theory.

An example like (38) is also given an arguably appropriate interpretation in the proposed account, if a downward-entailing quantifier like *no one* is decomposed into a negation and an existential quantifier, as proposed in Iatridou and Sichel (2011).

(38) No one even chats to each other. (from Dalrymple *et al.* (1998))

Given such decomposition, the sentence would be correctly predicted to mean “No one even chats to anyone else,” since the *qb* function would duplicate an existential quantifier in this case. Shown in Fig. 5 is the lexical entry for *no one* that embodies such decomposition, and the representation in (39) is the semantic representation that the grammar containing the lexical entry assigns to the sentence (38), disregarding the contribution of *even*.

(39) the(X , people(X),
not(some(y , member_of(y , X),
some(z , other(z , X , y),
chat_to(y , z))))))

Obviously, the word *no one* has to be associated with at least two lexical entries in the proposed account, since the lexical entry given in Fig. 5 only gives rise to partitive readings.

Now, the constraint given in (35) is adequate in dealing with simple cases, but it needs to be revised slightly, if the grammar is to be able to handle more complex examples like the following.

(40) Tom shouted and Mary cried each other’s names. (from Chaves (2014))

(41) John sent a Christmas card, and Mary sent a party invitation, to each other’s bosses. (from Kubota and Levine (2020, p. 105))

These examples both involve right-node raising, and we can envisage an analysis like the following, using the account of right-node raising defended in Yatabe and Tam (2021). In that HPSG-based account, a right-node-raised expression is allowed to be associated with different semantic representations in different conjuncts, as long as those semantic representations are alphabetic variants of each other. Thus, assuming that the DPs *Tom* and *Mary* are given i and j respectively as indices and that an index of the form $i + j$ denotes the set consisting of the denotation of i and the denotation

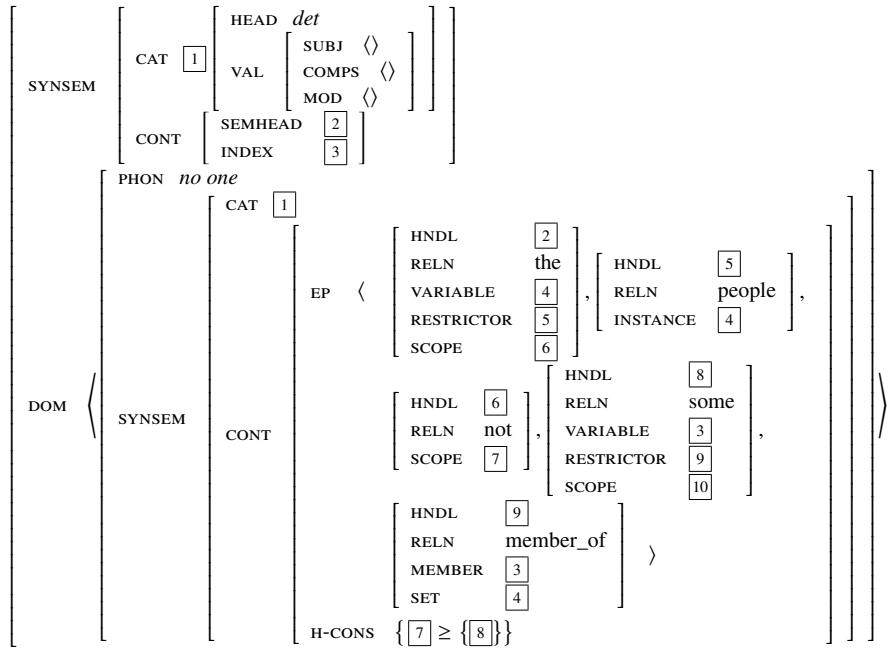

Figure 5: A lexical entry for *no one*

of j (i.e. the set consisting of Tom and Mary in the case at hand), the reciprocal pronoun *each other* in sentence (40) can conceivably be associated with a semantic representation of the form

$$(42) \text{ every}(y, \text{other}(y, i + j, i), \dots)$$

in the first conjunct and with a semantic representation of the form

$$(43) \text{ every}(z, \text{other}(z, i + j, j), \dots)$$

in the second conjunct (because $\text{qb}(i) = \text{qb}(j) = \text{every}$), and retain those two meanings even after right-node raising has applied. If we further assume that the noun *names* in this example is a dependent plural licensed by the immediately preceding reciprocal pronoun and is thus semantically number-neutral, the sentence as a whole is predicted to mean “Tom shouted the name (or names) of everyone in the set {Tom, Mary} other than Tom, and Mary cried the name (or names) of everyone in the set {Tom, Mary} other than Mary”. This seems to be an adequate prediction, but the grammar as it stands does not generate the semantic representation in question, because both (42) and (43) violate the constraint in (35).

I therefore propose to replace the constraint in (35) with the following constraint.

(44) The constraint on the predicate *other*:

1. Suppose that a given occurrence of a word (such as *each other*) has given rise to n subformulas of the form

$$Q(y_1, \text{other}(y_1, X_1, z_1), \dots),$$

...

$$Q(y_n, \text{other}(y_n, X_n, z_n), \dots),$$

where $n \geq 1$, such that the n subformulas are conjoined with each other and with nothing else and the n subformulas appear in this order in the given semantic representation. Then X_1, \dots, X_n must all be the same

variable of the form $u_1 + \dots + u_n$ such that for each i ($1 \leq i \leq n$), z_i ranges over u_i .

2. The second argument and the third argument of *other* cannot be identical to each other.

The statement in (44) that “the n subformulas are conjoined with each other and with nothing else and the n subformulas appear in this order in the given semantic representation” is meant to be vacuously true when $n = 1$. Assuming such an interpretation, the first clause of this revised constraint is equivalent to the constraint in (35) when $n = 1$.

Let us see how this revised constraint applies to the example in (40), which is associated with a semantic representation like the following in the proposed account.

- (45) $i = \text{Tom} \wedge j = \text{Mary}$
 $\wedge \text{and}(\text{every}(y, \text{other}(y, i + j, i),$
 $\quad \text{the}(v, \text{name_or_names_of}(v, y),$
 $\quad \quad \text{shouted}(i, v))),$
 $\quad \text{every}(z, \text{other}(z, i + j, j),$
 $\quad \quad \text{the}(w, \text{name_or_names_of}(w, z),$
 $\quad \quad \quad \text{cried}(j, w))))$

In this case, the word *each other* has given rise to two subformulas of the form $\text{every}(_, \text{other}(_, _, _))$, and those two subformulas are conjoined with each other and with nothing else in the representation. The third argument of the first occurrence of the predicate *other* ranges over i , the third argument of the second occurrence of *other* ranges over j , and the second argument of the first *other* and the second argument of the second *other* are both a variable of the form $i + j$, which is not identical either to i or to j , so the representation as a whole does satisfy the constraint in (44).

There is one more modification that needs to be made to the proposed theory of reciprocal pronouns. The theory that has been presented so far does not make correct predictions about the truth conditions of the following sentence.

- (46) They told each other’s wives lies about each other.
 (from Heim *et al.* (1991b))

As noted in Heim *et al.* (1991b), when the pronoun *they* here refers to the people A, B, and C, for example, the sentence seems to mean “A told B’s wife lies about B and told C’s wife lies about C, B told C’s wife lies about C and told A’s wife lies about A, and C told A’s wife lies about A and told B’s wife lies about B”; in order for the sentence to be true, it does not seem to be necessary for A to have told B’s wife lies about C, contradicting what the theory that has been presented so far predicts.

In order to accommodate this observation, I propose the following rule, which modifies MRS representations.

- (47) The Reciprocal Amalgamation Rule:
 Suppose a given MRS representation contains a pair of consecutive elementary predications of the form shown in (a) and another pair of consecutive elementary predications of the form shown in (b).

$$(a) \left[\begin{array}{ll} \text{HNDL} & \boxed{1} \\ \text{RELN} & \text{qb}(\boxed{7}) \\ \text{VARIABLE} & \boxed{3} \\ \text{RESTRICTOR} & \boxed{4} \\ \text{SCOPE} & \boxed{5} \end{array} \right], \left[\begin{array}{ll} \text{HNDL} & \boxed{4} \\ \text{RELN} & \text{other} \\ \text{INSTANCE} & \boxed{3} \\ \text{SET} & \boxed{6} \\ \text{CONTRAST} & \boxed{7} \end{array} \right]$$

$$(b) \left[\begin{array}{l} \text{HNDL} \\ \text{RELN} \\ \text{VARIABLE} \\ \text{RESTRICTOR} \\ \text{SCOPE} \end{array} \begin{array}{l} \boxed{2} \\ \text{qb}(\boxed{7}) \\ \boxed{3} \\ \boxed{4} \\ \boxed{5} \end{array} \right], \left[\begin{array}{l} \text{HNDL} \\ \text{RELN} \\ \text{INSTANCE} \\ \text{SET} \\ \text{CONTRAST} \end{array} \begin{array}{l} \boxed{4} \\ \text{other} \\ \boxed{3} \\ \boxed{6} \\ \boxed{7} \end{array} \right]$$

Suppose in addition that $\boxed{1}$ and $\boxed{2}$ are known to be identical with each other. Then one of the two pairs can be deleted from the MRS representation.

In the standard, constraint-based version of HPSG, two occurrences of the same word could in principle contribute identical sets of elementary predications to the semantic representation. Such a representation will be ruled out by the grammar in most cases, but when two occurrences of a reciprocal pronoun contribute identical sets of elementary predications, the rule in (47) may delete one of the two identical sets, making it possible for the semantic representation to be licensed by the grammar.

Let us see how this rule applies to example (46). When the two occurrences of *each other* contribute identical sets of elementary predications to the semantic representation, the grammar can initially assign to this sentence an illegitimate MRS representation that can be shown in the linear format as in (48).

$$(48) \text{ every}(y, \text{ member_of}(y, X), \\ \text{ every}(z, \text{ other}(z, X, y) \wedge \text{ other}(z, X, y), \\ \text{ the}(w, \text{ wife_or_wives_of}(w, z), \\ \text{ some}(v, \text{ lies_about}(v, z), \\ \text{ told}(y, w, v)))) \\ \wedge \text{ every}(z, \text{ other}(z, X, y) \wedge \text{ other}(z, X, y), \\ \text{ the}(w, \text{ wife_or_wives_of}(w, z), \\ \text{ some}(v, \text{ lies_about}(v, z), \\ \text{ told}(y, w, v))))))$$

In this illegitimate MRS representation (which is illegitimate because the elementary predications in it do not form a tree), the two occurrences of *every* are interpreted as being conjoined with each other, because two elementary predications sharing the same handle are supposed to be interpreted that way. The two occurrences of *other* are interpreted as being conjoined with each other in line 2 and in line 6 of the representation for the same reason. When the Reciprocal Amalgamation Rule is applied to this representation, two elementary predications coming from one occurrence of *each other* are deleted, yielding a legitimate MRS representation that can be shown in the linear format as in (49).

$$(49) \text{ every}(y, \text{ member_of}(y, X), \\ \text{ every}(z, \text{ other}(z, X, y), \\ \text{ the}(w, \text{ wife_or_wives_of}(w, z), \\ \text{ some}(v, \text{ lies_about}(v, z), \\ \text{ told}(y, w, v))))))$$

This legitimate MRS representation expresses the truth conditions that were described above.

The Reciprocal Amalgamation Rule will not play any role in the rest of the present section, but it will play a crucial role in Sect. 5 below.

3.3 The hidden-reciprocal *different*

Given the mechanisms for expressing distribution and reciprocity that have been presented, it is possible to capture the semantics of *different* in a straightforward manner.

The basic idea underlining the proposed account is that the word *different* in a sentence like (1) expresses a complex meaning that contains the meaning of a reciprocal pronoun. Thus, I will henceforth refer to the lexical item *different* used in a sentence like (1) as the hidden-reciprocal *different*. The proposed account assigns the semantic representation shown in (51) to the sentence in (50), when the adjective there is taken to be the hidden-reciprocal *different*.

(50) Anna and Bill like different films.

(51) $a = \text{Anna} \wedge b = \text{Bill}$
 $\wedge \text{some}(X, X = \{a, b\},$
 $\quad \text{every}(y, \text{member_of}(y, X),$
 $\quad \quad \text{some}(z, \text{and}(\text{film_or_films}(z),$
 $\quad \quad \quad \text{every}(w, \text{other}(w, X, y),$
 $\quad \quad \quad \quad \text{the}(v, \text{film_or_films}(v) \wedge \text{like}(w, v),$
 $\quad \quad \quad \quad \quad \text{different}(z, v))))),$
 $\quad \quad \quad \quad \quad \quad \text{like}(y, z))))$

Note that I am assuming (i) that the subject DP is given distributive interpretation either by DIST1 or by DIST2, (ii) that the nominal that is modified by *different* (i.e. *films* in the example at hand) is a dependent plural and is thus semantically number-neutral, (iii) that the object DP is headed by an unpronounced determiner whose interpretation is the same as that of the word *some*, and (iv) that the predicate *different* in (51) is a two-place predicate that is satisfied if and only if the denotation of its first argument is different from that of its second argument.

I am not claiming that the syntactic representation of a sentence like (50) contains a reciprocal pronoun, so the binding condition given in (30) is irrelevant here. The hidden-reciprocal *different* need not have a local syntactic antecedent.

It is the lexical entry for the hidden-reciprocal *different* shown in Fig. 6 that does most of the heavy lifting in the proposed account. This lexical entry is responsible for lines 5, 6, and 7 of the representation in (51). Most of the rest of the representation comes from the other words in the sentence; lines 1 and 2 come from the subject DP, line 3 comes from either DIST1 or DIST2, line 4 mostly comes from the noun *films* and a phonologically null determiner that is assumed to be at the left edge of the object DP, and line 8 comes from the verb. The predicate *and* in line 4 is supplied by the grammar rule that is responsible for interpreting a combination of a prenominal AP and a nominal (see footnote 9 of Yatabe and Tam (2021)). It is assumed that a formula of the form $\text{and}(P_1, \dots, P_n)$ is true if and only if P_1, \dots, P_n are all true.

Let us take a closer look at the contribution that the lexical entry of the hidden-reciprocal *different* makes. The symbol \oplus represents list concatenation. Thus the DOM|FIRST|SYNSEM|CONT|EP value of this lexical entry is a concatenation of three lists, viz. a list containing four elementary predications and two other lists, which are both described using the *copy* function. The first two elementary predications in this EP value, whose RELN values are described as $\text{qb}(\boxed{8})$ and *other* respectively, are responsible for line 5 of the representation in (51). These two elementary predications together express the same meaning as that of a reciprocal pronoun. The third elementary predication in the EP value is responsible for the presence of the predicate *the* in line 6 of (51), and the fourth elementary predication, whose RELN value is *different*, is responsible for line 7. The rest of the EP list, i.e. the portion of the EP list that is represented by

(52) $\text{copy}(\text{replace}(\text{vqb}(\boxed{3}), \text{vqb}(\boxed{9}), \text{lep}(\boxed{2})), \boxed{10})$

and

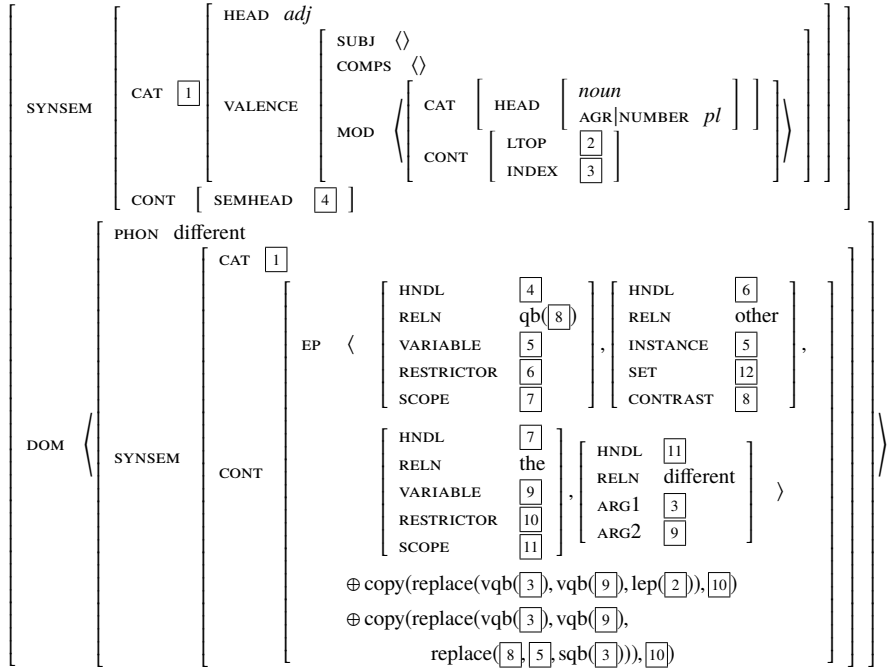

Condition: $\text{sqb}(3)$ contains 8.

Figure 6: The lexical entry for the hidden-reciprocal *different*

(53) $\text{copy}(\text{replace}(\text{vqb}(3), \text{vqb}(9), \text{replace}(8, 5, \text{sqb}(3))), 10)$,

is responsible for the restrictor of the quantifier *the* in line 6; (52) corresponds to “film_or_films(v)” and (53) corresponds to “like(w, v)”.

Intuitively, what (52) and (53) do is to create modified copies of some designated parts of the semantic representation and to use those newly created copies to specify the restrictor of *the*. For instance, in the case of the representation shown in (51), (52) took the subformula “film_or_films(z)” in line 4 and turned it into “film_or_films(v)”, while (53) took the subformula “like(y, z)” in line 8 and turned it into “like(w, v)”.

The five functions that are utilized in (52) and (53) are defined in (54), (55), (58), (60), and (61). The term *the list of elementary predications under*, used in (55) and (58), is defined in (56), the term *the pre-final form*, used in (55) and (60), is defined in (57), and the term *synonymous copy*, used in (61), is defined in (62). The term *locally resolved*, used in (58), is defined in (59).

(54) Definition of the *replace* function:

Let x and y be variables, and let L be a list of elementary predications. Then $\text{replace}(x, y, L)$ is the result of replacing all occurrences of x with y in L .

(55) Definition of the *sqb* function:

Suppose x is a variable bound by a quantifier. Suppose also that the MRS representation that x appears in is in the pre-final form. Then $\text{sqb}(x)$ is the list of elementary predications under the SCOPE value of the quantificational elementary predication that binds x .

(56) Definition of the term *the list of elementary predications under*:

The list of elementary predications under the handle h is that list of elementary

predications that is obtained by retaining those elementary predications whose `HNDL` values are either identical to or outscoped by h and deleting all the other elementary predications in the list of elementary predications that is part of the given MRS representation.

(57) Definition of the term *the pre-final form*:

Suppose a given MRS representation consists of a set of handle constraints C and a list of elementary predications R . Suppose also that R is a concatenation of one or more formulas of the form “`copy(,)`” (each of which stands for a list of elementary predications) and one or more lists L_1, \dots, L_n which are explicitly lists of elementary predications. Such an MRS representation is said to be in *the pre-final form* if and only if either the MRS representation consisting of C and $L_1 \oplus \dots \oplus L_n$ is already a resolved, legitimate MRS representation or that representation can be turned into a resolved, legitimate MRS representation by merely adding to its list of elementary predications (i.e. $L_1 \oplus \dots \oplus L_n$) some appropriate elementary predications that have no handle arguments. (In other words, such an MRS representation is said to be in the pre-final form if and only if the tree formed by the elementary predications involved is either already complete or only missing some items in leaf positions.)

(58) Definition of the *lep* function:

Let h be a handle contained in an MRS representation that is locally resolved below h . Then $\text{lep}(h)$ is the list of elementary predications under h .

(59) Definition of the term *locally resolved below*:

An MRS representation is *locally resolved below* the handle h at a given stage of the resolution process if and only if, at that stage, the elementary predications whose handles are known to be either identical to h or outscoped by h form a resolved, legitimate MRS representation.

(60) Definition of the *vqb* function:

Suppose x is a variable bound by a quantifier. Suppose also that the MRS representation that x appears in is in the pre-final form. Then $\text{vqb}(x)$ is the `VARIABLE` value of the quantificational elementary predication that binds x .

(61) Definition of the *copy* function:

Let L be a list of elementary predications that constitutes a resolved, legitimate MRS representation, and let h be a handle. Then $\text{copy}(L, h)$ is a synonymous copy of L whose top handle is h .

(62) Definition of the term *synonymous copy*:

Let L be a list of elementary predications that constitutes a resolved, legitimate MRS representation. Then L' is a *synonymous copy* of L if and only if (i) L and L' are identical except for handles and variables, (ii) two paths in L' end in the same handle if and only if those paths end in the same handle in L , (iii) two paths in L' end in the same variable if and only if those paths end in the same variable in L , and (iv) if a path in L ends in a variable free in L (i.e. a variable that does not occur as the `VARIABLE` value of a quantificational elementary predication inside L), then that path ends in that same variable in L' as well.

The *sqb* function is so named because it is a function that maps a variable to the scope of the quantifier that binds that variable. It is because of the variable-binding condition that this function is capable of picking out the list of elementary predications that it is supposed to pick out. The *vqb* function is so named because it maps a variable to the `VARIABLE` value of the quantifier that binds that variable. The function is *not* an

identity function, as will become apparent in Sect. 5 below. The *copy* function creates a copy of the first argument that is to be placed at the location indicated by the second argument.

It is assumed, as in Yatabe and Tam (2021), that resolution of an MRS representation is performed incrementally. At each step of the resolution process, one of the following three things may happen: (i) a constraint that requires two or more handles to be identical may be added to the representation, (ii) a rule (such as the Reciprocal Amalgamation Rule) that modifies the MRS representation may be applied, and (iii) a function such as the *lep* function may return a value. Once a sufficient number of such steps have been taken and the MRS representation is in the pre-final form in the sense defined in (57), it becomes possible for the *sqb* function and the *vqb* function to return values, which in turn makes it possible for the *replace* function and the *copy* function to turn the MRS representation into its final state.

In the case of (51), the *copy* function placed the following two things in the restrictor of *the*, the position indicated by tag [10] in the lexical entry for *different*.

- (63) $\text{replace}(\text{vqb}(\boxed{3}), \text{vqb}(\boxed{9}), \text{lep}(\boxed{2}))$
 $= \text{replace}(\text{vqb}(z), \text{vqb}(v), \langle \text{film_or_films}(z) \rangle)$
 $= \text{replace}(z, v, \langle \text{film_or_films}(z) \rangle)$
 $= \langle \text{film_or_films}(v) \rangle$
- (64) $\text{replace}(\text{vqb}(\boxed{3}), \text{vqb}(\boxed{9}), \text{replace}(\boxed{8}, \boxed{5}, \text{sqb}(\boxed{3})))$
 $= \text{replace}(\text{vqb}(z), \text{vqb}(v), \text{replace}(y, w, \langle \text{like}(y, z) \rangle))$
 $= \text{replace}(z, v, \langle \text{like}(w, z) \rangle)$
 $= \langle \text{like}(w, v) \rangle$

Since the proposed lexical entry for the hidden-reciprocal *different* uses the *qb* function just like the lexical entry for *each other*, the grammar can assign to the sentence in (65) the semantic representation shown in (66), in which the quantifier meaning expressed by *most* has been duplicated.

- (65) Most students saw different films. (from Kamp and Reyle (1993, p. 479))
- (66) $\text{the}(X, \text{students}(X),$
 $\text{most}(y, \text{member_of}(y, X),$
 $\text{some}(z, \text{and}(\text{film_or_films}(z),$
 $\text{most}(w, \text{other}(w, X, y),$
 $\text{the}(v, \text{film_or_films}(v) \wedge \text{saw}(w, v),$
 $\text{different}(z, v))))),$
 $\text{saw}(y, z)))))$

Likewise, assuming that the determiner *no* is associated with the lexical entry given in Fig. 7, which is related in the expected way to the lexical entry for *no one* in Fig. 5, the sentence in (67) can be assigned the semantic representation shown in (68), in which the *qb* function has duplicated the existential quantifier.

- (67) No students saw different movies.
- (68) $\text{the}(X, \text{students}(X),$
 $\text{not}(\text{some}(y, \text{member_of}(y, X),$
 $\text{some}(z, \text{and}(\text{film_or_films}(z),$
 $\text{some}(w, \text{other}(w, X, y),$
 $\text{the}(v, \text{film_or_films}(v) \wedge \text{saw}(w, v),$
 $\text{different}(z, v))))),$
 $\text{saw}(y, z)))))$

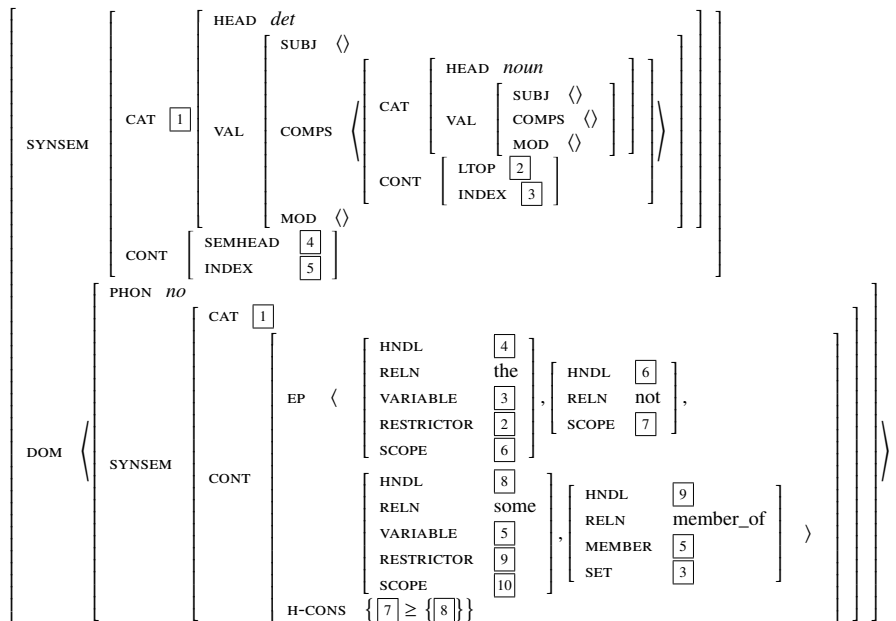

Figure 7: A lexical entry for *no*

The representation in (66) means that “most of the students saw a (possibly singleton) set of movies such that most of the other students saw a (possibly singleton) set of movies that is different from that set.” The representation in (68) means that “none of the students saw a (possibly singleton) set of movies such that some other student saw a (possibly singleton) set of movies that is different from that set.” These are arguably adequate descriptions of the truth conditions of the internal readings of sentences (65) and (67).

The proposed lexical entry for the hidden-reciprocal *different* contains a condition that requires that $\text{sqb}(\boxed{3})$ should contain $\boxed{8}$. This requirement has the effect of preventing sentences like (69), taken from Carlson (1987), from having internal readings.

(69) The two gorillas saw a woman who fed different men.

It is noted in Carlson (1987) that this sentence does not have a reading in which it means that “Gorilla 1 saw a woman who fed man A, gorilla 2 saw a woman who fed man B, and man A and man B were different men.” The reason this observation is correctly accounted for by the proposed theory is the following. In the lexical entry for the hidden-reciprocal *different*, tag $\boxed{3}$ is the index of the nominal modified by *different*, while $\boxed{8}$ is the CONTRAST argument of the *other* predicate, and is thus typically an individual-denoting variable that ranges over a set-denoting variable contributed by the antecedent of *different*, due to the effect of the constraint on the predicate *other*, stated in (44). As a result, in the case of example (69), the condition that requires $\text{sqb}(\boxed{3})$ to contain $\boxed{8}$ forces the DP *different men* to take the matrix clause as its scope, since otherwise the scope of the quantifier that binds the index of *different men* would not contain the individual-denoting variable that ranges over the set-denoting variable contributed by *the two gorillas*. The example ends up having no internal reading because the relative clause here is a scope island and does not allow *different men* to

have the matrix clause as its scope.²

Charnavel (2015) espouses the view that *different* in a sentence like (1) can be given an internal reading even when the adjective is separated from its antecedent by a scope island, a view that leads her to explicitly repudiate a theory similar in several important respects to what has just been presented, although she claims that an analogous theory is appropriate for *different* in sentence (2). Her view is based on the following example, discussed in Beck (2000).

- (70) Otilie und Maria haben Bücher gelesen, die zu verschiedenen Schlüssen
 Otilie and Maria have books read which to different conclusions
 kamen.
 came
 ‘Otilie and Maria read books that came to different conclusions.’

This example, however, does not show what Charnavel claims it does. The antecedent of the symmetrical adjective here may be the gapped subject of the relative clause, not the subject of the matrix clause.

4 Internal readings of *the same* in partitive constructions

The analysis of the hidden-reciprocal *different* that has been presented is arguably applicable, with minor modifications, to other symmetrical predicates. In the case of the adverb *differently*, for instance, the word could be associated with a lexical entry that gives it the same meaning that the phrase *in different ways* is given when the adjective in it is the hidden-reciprocal *different*. Such an analysis will assign adequate truth conditions to sentences like *Anna and Bill aged differently*, and at the same time, it will entail that the word *differently* used in a sentence like (14) is a separate word whose meaning does not involve that of the hidden-reciprocal *different*. A lexical item whose meaning involves a hidden reciprocal cannot be used in a sentence like (14), which contains nothing that could serve as the antecedent of a reciprocal.

The issue posed by sentences like (24), however, requires special treatment. In order to deal with this issue, I suggest that the expression *the same* should be associated with the lexical entry shown in Fig. 8, and that words like *some* and *of* that are used in partitive constructions should be associated with lexical entries like those given in Fig. 9 and Fig. 10. Given these lexical entries, the sentences in (71a) and (72a) can be associated with the semantic representations in (71b) and (72b) respectively.

- (71) a. Anna and Bill saw the same movies.
 b. $a = \text{Anna} \wedge b = \text{Bill}$
 $\wedge \text{some}(X, X = \{a, b\},$
 $\text{every}(y, \text{member_of}(y, X),$
 $\text{the}(Z, \text{and}(\text{movies}(Z),$
 $\text{every}(w, \text{other}(w, X, y),$
 $\text{the}(U, \text{movies}(U) \wedge \text{saw}(w, U),$
 $\text{identical}(Z, U))))),$
 $\text{saw}(y, Z))))$

²As discussed in Dalrymple *et al.* (1999), relative clauses are not always scope islands. The prediction of the theory proposed in the text is that a symmetrical predicate contained in a relative clause cannot take an expression outside it as its antecedent when that relative clause is functioning as a scope island.

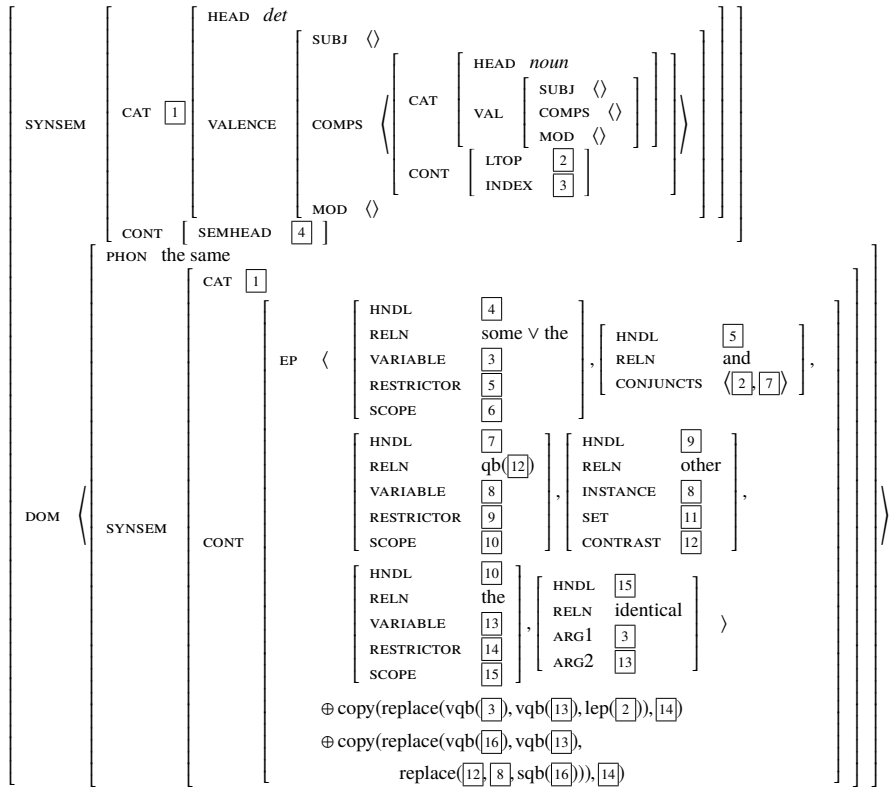

Condition 1: [16] is either identical to [3] or bound by a quantifier such that one of the elementary predications that constitute its restrictor is either of the form “part_of([16], [3])” or of the form “member_of([16], [3])”.

Condition 2: $\text{sqb}([16])$ contains [12].

Figure 8: A lexical entry for the hidden-reciprocal *the same*

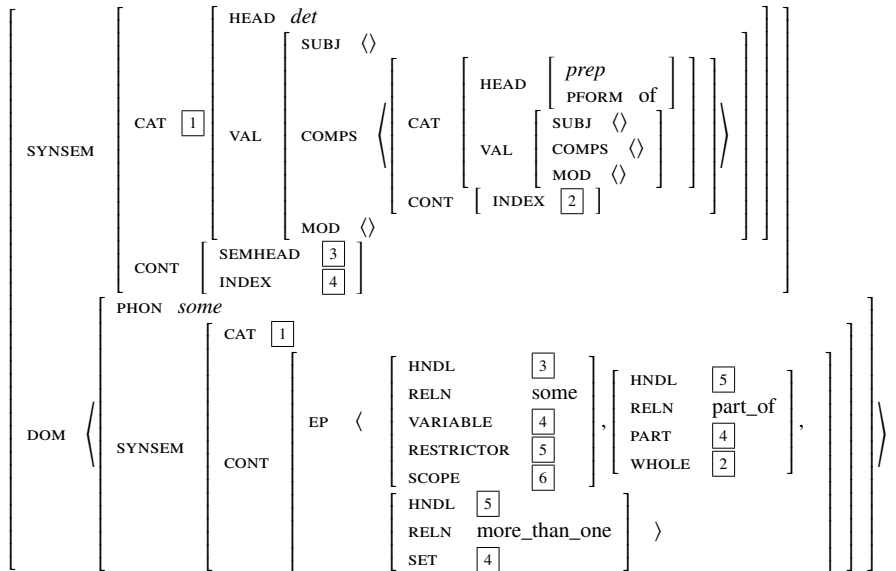

Figure 9: The lexical entry for the partitive *some*

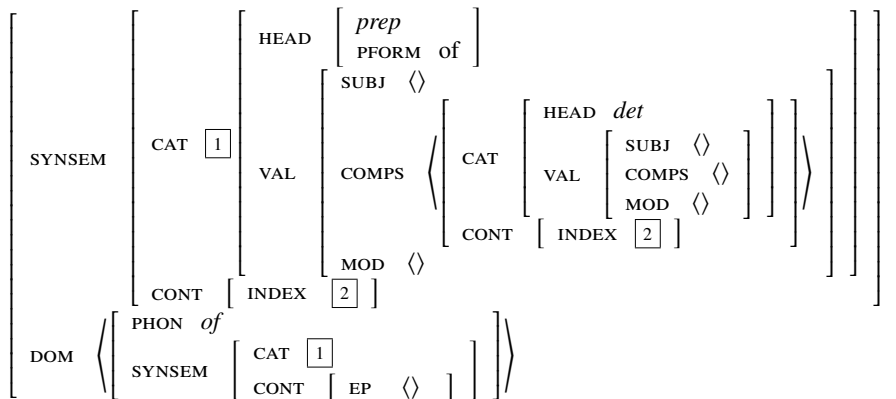

Figure 10: The lexical entry for the partitive *of*

- (72) a. Anna and Bill saw some of the same movies.
 b. $a = \text{Anna} \wedge b = \text{Bill}$
 $\wedge \text{some}(X, X = \{a, b\},$
 $\quad \text{every}(y, \text{member_of}(y, X),$
 $\quad \quad \text{the}(Z, \text{and}(\text{movies}(Z),$
 $\quad \quad \quad \text{every}(w, \text{other}(w, X, y),$
 $\quad \quad \quad \quad \text{the}(U, \text{movies}(U) \wedge \text{saw}(w, U),$
 $\quad \quad \quad \quad \quad \text{identical}(Z, U))))),$
 $\quad \quad \quad \text{some}(V, \text{part_of}(V, Z) \wedge \text{more_than_one}(V),$
 $\quad \quad \quad \quad \text{saw}(y, V))))))$

In (71b), lines 1 and 2 come from the subject DP, line 3 comes from a silent distributor, namely either DIST1 or DIST2, the elementary predication “*movies(Z)*” in line 4 comes from the NP *movies*, the rest of line 4 and lines 5, 6, and 7 come from *the same*, and line 8 comes from the verb *saw*. The predicate *every* in line 5 has been duplicated there by the *qb* function, and the restrictor of *the* on line 6 is a conjunction of a modified copy of part of line 4 and a modified copy of line 8, both produced by the *replace* function and the *copy* function.

The way the representation in (72b) is analogous. Lines 1 to 7 are in fact identical to the corresponding lines in (71b). Line 8 comes from the expression *some of*, and line 9 comes from the verb *saw*. The restrictor of *the* on line 6 is a conjunction of a modified copy of part of line 4 and a modified copy of line 9.

What is special about the proposed lexical entry for *the same* is Condition 1, which requires that [16] should either be identical to [3] or be bound by a quantifier such that one of the elementary predications that constitute its restrictor is either of the form “*part_of*([16], [3])” or of the form “*member_of*([16], [3])”. [16] has to be identical to [3] in a case like (71b), which does not involve a partitive construction. In contrast, in a case like (72b), which does involve a partitive construction, [16] can be bound by a quantifier whose restrictor contains an elementary predication of the form *part_of*([16], [3]), and not be identical to [3]. It is this feature of the lexical entry that allows part of what is placed in the restrictor of the second *the* in (72b) to be a modified copy of the nuclear scope of *some of the same movies*, and not a modified copy of the nuclear scope of *the same movies*.

I would like to point out here that, in the analysis presented in this section, the partitive construction in a sentence like (72a) is treated as a perfectly normal partitive construction. This is arguably a strength of the theory proposed in the present article.

Another thing that I would like to note here is that, due to the working of the *qb* function, the proposed account gives rise to reasonable truth conditions even when the antecedent of *the same* is a DP headed by a determiner like *most*. For instance, sentences (73a) and (74a) are associated with the arguably adequate semantic representations in (73b) and (74b) respectively.

- (73) a. Most students saw the same film. (from Kamp and Reyle (1993, p. 473))
 b. $\text{the}(X, \text{students}(X),$
 $\quad \text{most}(y, \text{member_of}(y, X),$
 $\quad \quad \text{some}(z, \text{and}(\text{film}(z),$
 $\quad \quad \quad \text{most}(w, \text{other}(w, X, y),$
 $\quad \quad \quad \quad \text{the}(v, \text{film}(v) \wedge \text{saw}(w, v),$
 $\quad \quad \quad \quad \quad \text{identical}(z, v))))),$
 $\quad \quad \quad \text{saw}(y, z))))$

- (74) a. No students read the same book. (from Zuber (2017))

b. $\text{the}(X, \text{students}(X),$
 $\text{not}(\text{some}(y, \text{member_of}(y, X),$
 $\text{some}(z, \text{and}(\text{book}(z),$
 $\text{some}(w, \text{other}(w, X, y),$
 $\text{the}(v, \text{book}(v) \wedge \text{read}(w, v),$
 $\text{identical}(z, v))))),$
 $\text{read}(y, z))))))$

The *qb* function has duplicated the quantifier *most* in (73b) and the quantifier *some* in (74b).

5 Sentences containing more than one symmetrical predicate

Let me next show that the proposed theory does not falter when it is applied to examples involving more than one symmetrical predicate, unlike the parasitic-scope theory, discussed in Sect. 2. I will demonstrate how the theory assigns adequate truth conditions to the following sentence.

(75) John and Bill said the same thing to different people.

In order to deal with this type of sentence, we need to rely on the two rules given in (76) and (77), which Yatabe and Tam (2021) propose in order to assign appropriate truth conditions to sentences such as *Every woman is smiling and every man is frowning who came in together*, discussed in Fox and Johnson (2016).³ The expression *locally resolved*, which is used in (76), was defined in (59) above.

(76) MRS Adjustment Rule 1:

On condition (i) that a given MRS representation is locally resolved below each of the n handles $\boxed{1}, \dots, \boxed{n}$, (ii) that no two of the $n + 1$ handles $\boxed{0}, \dots, \boxed{n}$ are known to be identical to each other, and (iii) that the given MRS representation does not contain a subformula of the form $\text{lep}(x)$, where x is one of the n handles $\boxed{1}, \dots, \boxed{n}$, an elementary predication of the form

$$\left[\begin{array}{l} \text{HNDL} \quad \boxed{0} \\ \text{RELN} \quad \text{and} \\ \text{CONJUNCTS} \quad \langle \boxed{1}, \dots, \boxed{n} \rangle \end{array} \right]$$

can be removed from the MRS representation, leaving behind a handle constraint that requires that $\boxed{0}, \dots, \boxed{n}$ be identical to each other.

(77) MRS Adjustment Rule 2:

Suppose that a given MRS representation contains n elementary predications of the following form, that these n elementary predications appear in this order in the MRS representation, and that there is no other elementary predication in

³The rule given in (76) differs from what is proposed in Yatabe and Tam (2021) in two respects. First, the version of the rule proposed in Yatabe and Tam (2021) did not have the third condition. And second, the second condition of the rule proposed in that work only required that no two of the n handles $\boxed{1}, \dots, \boxed{n}$ should be known to be identical to each other. The rule given in (77) is likewise slightly different from what is presented in Yatabe and Tam (2021). First, the version given here makes reference to the linear order of the elementary predications. Second, the version presented here contains a new requirement that there is no other elementary predication in the MRS representation that shares the same RESTRICTOR value and the same SCOPE value with the n elementary predications. And third, the version given here does not mention “numerical determiners” since prenominal numerals are viewed as adjectives, not determiners, in the present work. See the treatment of example (26) above.

the representation that shares the same RESTRICTOR value and the same SCOPE value with these n elementary predications.

$$\left[\begin{array}{l} \text{HNDL} \\ \text{RELN} \\ \text{VAR} \\ \text{RESTRICTOR} \\ \text{SCOPE} \end{array} \begin{array}{l} \boxed{h_1} \\ \boxed{1} \\ \boxed{v_1} \\ \boxed{2} \\ \boxed{3} \end{array} \right], \dots, \left[\begin{array}{l} \text{HNDL} \\ \text{RELN} \\ \text{VAR} \\ \text{RESTRICTOR} \\ \text{SCOPE} \end{array} \begin{array}{l} \boxed{h_n} \\ \boxed{1} \\ \boxed{v_n} \\ \boxed{2} \\ \boxed{3} \end{array} \right]$$

Then these n elementary predications can be replaced by a single elementary predication of the following form, if $\boxed{h_1}, \dots, \boxed{h_n}$ are known to be identical with each other and $\boxed{v_1}, \dots, \boxed{v_n}$ are distinct from each other.

$$\left[\begin{array}{l} \text{HNDL} \\ \text{RELN} \\ \text{VAR} \\ \text{RESTRICTOR} \\ \text{SCOPE} \end{array} \begin{array}{l} \boxed{h_1} \\ \boxed{1} \\ \boxed{v_1 + \dots + v_n} \\ \boxed{2} \\ \boxed{3} \end{array} \right]$$

The newly created elementary predication is to be placed at the position where the leftmost of the deleted elementary predications was located, and is to be interpreted in the expected way. For instance, when the denotation of $\boxed{1}$ is “every”, the resultant elementary predication is interpreted as saying “Every n -tuple that makes the restrictor true makes the nuclear scope true as well”.

Once the MRS Adjustment Rules 1 and 2 are added to the grammar, sentence (75) can be given appropriate truth conditions in the following way. Suppose (i) that the RELN value of the leftmost elementary predication that the expression *the same* contributes to the representation is *some*, not *the*, (ii) that the elementary predication coming from *the same* whose RELN value is *some* and the elementary predication coming from the unpronounced determiner preceding *different* whose RELN value is *some* share the same HNDL value, the same RESTRICTOR value, and the same SCOPE value, (iii) that the two elementary predications whose RELN values are *the* (one coming from *the same* and the other one coming from *different*) likewise share the same HNDL value, the same RESTRICTOR value, and the same SCOPE value, and (iv) that the two elementary predications from *the same* that have the meaning of a reciprocal pronoun and the two elementary predications from *different* that have the meaning of a reciprocal pronoun are identical with each other except for the HNDL values of the elementary predications whose RELN values are determined by the *qb* function. Given these assumptions, the sentence can initially give rise to the illegitimate MRS representation shown in (78). Since some functions do not return values at this point, the representation cannot be shown in the linear format in its entirety; here and in some of the illustrations below, I mix the linear format and the official MRS format in a way that is strictly speaking incoherent, aiming to make the representations as readable as possible without introducing any unclarity or ambiguity.

$$(78) \quad \begin{array}{l} j = \text{John} \wedge b = \text{Bill} \\ \wedge \text{some}(X, X = \{j, b\}, \\ \quad \text{every}(y, \text{member_of}(y, X), \\ \quad \quad \text{some}(z, \text{and}(\boxed{2} \text{thing}(z), \\ \quad \quad \quad \text{every}(w, \text{other}(w, X, y) \wedge \text{other}(w, X, y), \\ \quad \quad \quad \quad \text{the}(v, \boxed{1}), \\ \quad \quad \quad \quad \quad \text{identical}(z, v) \wedge \text{different}(u, t)) \end{array}$$

$$\begin{aligned}
& \wedge \text{the}(t, \boxed{1}), \\
& \quad \text{identical}(z, v) \wedge \text{different}(u, t))) \\
& \wedge \text{and}(\boxed{3} \text{person_or_people}(u), \\
& \quad \text{every}(w, \text{other}(w, X, y) \wedge \text{other}(w, X, y), \\
& \quad \quad \text{the}(v, \boxed{1}), \\
& \quad \quad \quad \text{identical}(z, v) \wedge \text{different}(u, t)) \\
& \quad \quad \wedge \text{the}(t, \boxed{1}), \\
& \quad \quad \quad \text{identical}(z, v) \wedge \text{different}(u, t))), \\
& \quad \text{said}(y, z, u)) \\
& \wedge \text{some}(u, \text{and}(\boxed{2} \text{thing}(z), \\
& \quad \text{every}(w, \text{other}(w, X, y) \wedge \text{other}(w, X, y), \\
& \quad \quad \text{the}(v, \boxed{1}), \\
& \quad \quad \quad \text{identical}(z, v) \wedge \text{different}(u, t)) \\
& \quad \quad \wedge \text{the}(t, \boxed{1}), \\
& \quad \quad \quad \text{identical}(z, v) \wedge \text{different}(u, t))) \\
& \wedge \text{and}(\boxed{3} \text{person_or_people}(u), \\
& \quad \text{every}(w, \text{other}(w, X, y) \wedge \text{other}(w, X, y), \\
& \quad \quad \text{the}(v, \boxed{1}), \\
& \quad \quad \quad \text{identical}(z, v) \wedge \text{different}(u, t)) \\
& \quad \quad \wedge \text{the}(t, \boxed{1}), \\
& \quad \quad \quad \text{identical}(z, v) \wedge \text{different}(u, t))), \\
& \quad \text{said}(y, z, u))) \\
& \bigcirc (\text{copy}(\text{replace}(\text{vqb}(z), \text{vqb}(v), \text{lep}(\boxed{2})), \boxed{1}), \boxed{1}) \\
& \quad \oplus \text{copy}(\text{replace}(\text{vqb}(z), \text{vqb}(v), \text{replace}(y, w, \text{sqb}(z))), \boxed{1}), \boxed{1}) \\
& \quad \oplus \text{copy}(\text{replace}(\text{vqb}(u), \text{vqb}(t), \text{lep}(\boxed{3})), \boxed{1}), \boxed{1}) \\
& \quad \oplus \text{copy}(\text{replace}(\text{vqb}(u), \text{vqb}(t), \text{replace}(y, w, \text{sqb}(u))), \boxed{1}), \boxed{1}))
\end{aligned}$$

The representation in (78), which is shown partially in the traditional, linear format but is supposed to be an MRS representation, is illegitimate as an MRS representation because some (in fact many) elementary predications appear in multiple places and also because the variable-binding condition is violated. The symbol \bigcirc represents the non-deterministic shuffle operation. In the representation above, the symbol is meant to combine two lists of elementary predications, one depicted in the linear format and another one expressed as a concatenation of four lists, each of which is created by the *copy* function.

When the MRS Adjustment Rule 2 is applied to the second and the third occurrence of *some*, the following representation results.

$$\begin{aligned}
(79) \quad & j = \text{John} \wedge b = \text{Bill} \\
& \wedge \text{some}(X, X = \{j, b\}, \\
& \quad \text{every}(y, \text{member_of}(y, X), \\
& \quad \quad \text{some}(z + u, \text{and}(\boxed{2} \text{thing}(z), \\
& \quad \quad \quad \text{every}(w, \text{other}(w, X, y) \wedge \text{other}(w, X, y), \\
& \quad \quad \quad \quad \text{the}(v, \boxed{1}), \\
& \quad \quad \quad \quad \quad \text{identical}(z, v) \wedge \text{different}(u, t)) \\
& \quad \quad \quad \quad \wedge \text{the}(t, \boxed{1}), \\
& \quad \quad \quad \quad \quad \quad \text{identical}(z, v) \wedge \text{different}(u, t)))) \\
& \quad \wedge \text{and}(\boxed{3} \text{person_or_people}(u), \\
& \quad \quad \text{every}(w, \text{other}(w, X, y) \wedge \text{other}(w, X, y), \\
& \quad \quad \quad \text{the}(v, \boxed{1}), \\
& \quad \quad \quad \quad \text{identical}(z, v) \wedge \text{different}(u, t)) \\
& \quad \quad \quad \wedge \text{the}(t, \boxed{1}),
\end{aligned}$$

$$\begin{aligned}
& \text{identical}(z, v) \wedge \text{different}(u, t))), \\
& \text{said}(y, z, u))) \\
\circ & (\text{copy}(\text{replace}(\text{vqb}(z), \text{vqb}(v), \text{lep}(\boxed{2})), \boxed{1})) \\
\oplus & \text{copy}(\text{replace}(\text{vqb}(z), \text{vqb}(v), \text{replace}(y, w, \text{sqb}(z))), \boxed{1})) \\
\oplus & \text{copy}(\text{replace}(\text{vqb}(u), \text{vqb}(t), \text{lep}(\boxed{3})), \boxed{1})) \\
\oplus & \text{copy}(\text{replace}(\text{vqb}(u), \text{vqb}(t), \text{replace}(y, w, \text{sqb}(u))), \boxed{1}))
\end{aligned}$$

The variable newly created by the MRS Adjustment Rule 2 here is $z + u$ rather than $u + z$ because the quantificational elementary predication that binds z precedes the quantificational elementary predication that binds u . The order of elementary predications, which unfortunately becomes invisible when the MRS representation is depicted using the conventional, linear format, preserves the order of the words that have given rise to them.

Next, if we apply the MRS Adjustment Rule 2 to the two occurrences of *the* (which look like four occurrences in the linear format), the following representation results.

$$\begin{aligned}
(80) \quad & j = \text{John} \wedge b = \text{Bill} \\
& \wedge \text{some}(X, X = \{j, b\}, \\
& \quad \text{every}(y, \text{member_of}(y, X), \\
& \quad \quad \text{some}(z + u, \text{and}(\boxed{2} \text{thing}(z), \\
& \quad \quad \quad \text{every}(w, \text{other}(w, X, y) \wedge \text{other}(w, X, y), \\
& \quad \quad \quad \quad \text{the}(v + t, \boxed{1}), \\
& \quad \quad \quad \quad \quad \text{identical}(z, v) \wedge \text{different}(u, t)))) \\
& \quad \wedge \text{and}(\boxed{3} \text{person_or_people}(u), \\
& \quad \quad \text{every}(w, \text{other}(w, X, y) \wedge \text{other}(w, X, y), \\
& \quad \quad \quad \text{the}(v + t, \boxed{1}), \\
& \quad \quad \quad \quad \text{identical}(z, v) \wedge \text{different}(u, t))), \\
& \text{said}(y, z, u))) \\
\circ & (\text{copy}(\text{replace}(\text{vqb}(z), \text{vqb}(v), \text{lep}(\boxed{2})), \boxed{1})) \\
\oplus & \text{copy}(\text{replace}(\text{vqb}(z), \text{vqb}(v), \text{replace}(y, w, \text{sqb}(z))), \boxed{1})) \\
\oplus & \text{copy}(\text{replace}(\text{vqb}(u), \text{vqb}(t), \text{lep}(\boxed{3})), \boxed{1})) \\
\oplus & \text{copy}(\text{replace}(\text{vqb}(u), \text{vqb}(t), \text{replace}(y, w, \text{sqb}(u))), \boxed{1}))
\end{aligned}$$

The variable newly created by the MRS Adjustment Rule 2 here is $v + t$ rather than $t + v$ because the quantificational elementary predication that binds v precedes the quantificational elementary predication that binds t .

It is necessary to let the *lep* function return values at this point, and it is possible to do so because the representation in (80) is locally resolved below $\boxed{2}$ as well as below $\boxed{3}$. After the function returns values, the representation takes the form shown in (81).

$$\begin{aligned}
(81) \quad & j = \text{John} \wedge b = \text{Bill} \\
& \wedge \text{some}(X, X = \{j, b\}, \\
& \quad \text{every}(y, \text{member_of}(y, X), \\
& \quad \quad \text{some}(z + u, \text{and}(\text{thing}(z), \\
& \quad \quad \quad \text{every}(w, \text{other}(w, X, y) \wedge \text{other}(w, X, y), \\
& \quad \quad \quad \quad \text{the}(v + t, \boxed{1}), \\
& \quad \quad \quad \quad \quad \text{identical}(z, v) \wedge \text{different}(u, t)))) \\
& \quad \wedge \text{and}(\text{person_or_people}(u), \\
& \quad \quad \text{every}(w, \text{other}(w, X, y) \wedge \text{other}(w, X, y), \\
& \quad \quad \quad \text{the}(v + t, \boxed{1}), \\
& \quad \quad \quad \quad \text{identical}(z, v) \wedge \text{different}(u, t))), \\
& \text{said}(y, z, u))) \\
\circ & (\text{copy}(\text{replace}(\text{vqb}(z), \text{vqb}(v), \langle \text{thing}(z) \rangle), \boxed{1}))
\end{aligned}$$

$$\begin{aligned}
&\oplus \text{copy}(\text{replace}(\text{vqb}(z), \text{vqb}(v), \text{replace}(y, w, \text{sqb}(z))), \boxed{1}) \\
&\oplus \text{copy}(\text{replace}(\text{vqb}(u), \text{vqb}(t), \langle \text{person_or_people}(u) \rangle), \boxed{1}) \\
&\oplus \text{copy}(\text{replace}(\text{vqb}(u), \text{vqb}(t), \text{replace}(y, w, \text{sqb}(u))), \boxed{1})
\end{aligned}$$

At this point, the representation is locally resolved under the top handle of each argument of both occurrences of *and*, and the representation no longer contains $\text{lep}(\boxed{2})$ or $\text{lep}(\boxed{3})$, so we can apply the MRS Adjustment Rule 1 to both occurrences of *and*, yielding the following representation. Note that, in depicting MRS representations in the linear format, I am using the string “and” to represent conjunction expressed by an elementary predication whose RELN value is *and*, while using the symbol “ \wedge ” to represent conjunction expressed by shared handles.

$$\begin{aligned}
(82) \quad &j = \text{John} \wedge b = \text{Bill} \\
&\wedge \text{some}(X, X = \{j, b\}, \\
&\quad \text{every}(y, \text{member_of}(y, X), \\
&\quad \quad \text{some}(z + u, \text{thing}(z) \\
&\quad \quad \quad \wedge \text{every}(w, \text{other}(w, X, y) \wedge \text{other}(w, X, y), \\
&\quad \quad \quad \quad \text{the}(v + t, \boxed{1}, \\
&\quad \quad \quad \quad \quad \text{identical}(z, v) \wedge \text{different}(u, t))) \\
&\quad \quad \quad \wedge \text{person_or_people}(u) \\
&\quad \quad \quad \wedge \text{every}(w, \text{other}(w, X, y) \wedge \text{other}(w, X, y), \\
&\quad \quad \quad \quad \text{the}(v + t, \boxed{1}, \\
&\quad \quad \quad \quad \quad \text{identical}(z, v) \wedge \text{different}(u, t))), \\
&\quad \quad \quad \text{said}(y, z, u))) \\
&\circ (\text{copy}(\text{replace}(\text{vqb}(z), \text{vqb}(v), \langle \text{thing}(z) \rangle), \boxed{1}) \\
&\quad \oplus \text{copy}(\text{replace}(\text{vqb}(z), \text{vqb}(v), \text{replace}(y, w, \text{sqb}(z))), \boxed{1}) \\
&\quad \oplus \text{copy}(\text{replace}(\text{vqb}(u), \text{vqb}(t), \langle \text{person_or_people}(u) \rangle), \boxed{1}) \\
&\quad \oplus \text{copy}(\text{replace}(\text{vqb}(u), \text{vqb}(t), \text{replace}(y, w, \text{sqb}(u))), \boxed{1})
\end{aligned}$$

This representation can undergo the modification specified in the Reciprocal Amalgamation Rule, since the HNDL value of *every* on line 5 and the HNDL value of *every* on line 9 are now known to be identical. What is shown in (83) is the result of the modification.

$$\begin{aligned}
(83) \quad &j = \text{John} \wedge b = \text{Bill} \\
&\wedge \text{some}(X, X = \{j, b\}, \\
&\quad \text{every}(y, \text{member_of}(y, X), \\
&\quad \quad \text{some}(z + u, \text{thing}(z) \\
&\quad \quad \quad \wedge \text{person_or_people}(u) \\
&\quad \quad \quad \wedge \text{every}(w, \text{other}(w, X, y), \\
&\quad \quad \quad \quad \text{the}(v + t, \boxed{1}, \\
&\quad \quad \quad \quad \quad \text{identical}(z, v) \wedge \text{different}(u, t))), \\
&\quad \quad \quad \text{said}(y, z, u))) \\
&\circ (\text{copy}(\text{replace}(\text{vqb}(z), \text{vqb}(v), \langle \text{thing}(z) \rangle), \boxed{1}) \\
&\quad \oplus \text{copy}(\text{replace}(\text{vqb}(z), \text{vqb}(v), \text{replace}(y, w, \text{sqb}(z))), \boxed{1}) \\
&\quad \oplus \text{copy}(\text{replace}(\text{vqb}(u), \text{vqb}(t), \langle \text{person_or_people}(u) \rangle), \boxed{1}) \\
&\quad \oplus \text{copy}(\text{replace}(\text{vqb}(u), \text{vqb}(t), \text{replace}(y, w, \text{sqb}(u))), \boxed{1})
\end{aligned}$$

Now that the MRS representation is in the pre-final form in the sense defined in (57), we let the *sqb*, *vqb*, and *replace* functions return values, assuming the following convention.

$$(84) \quad \text{replace}(w + x, y + z, F) \equiv \text{replace}(w, y, \text{replace}(x, z, F))$$

Given this convention, the *replace* functions in the last four lines of (83) will return the following values.

- (85) a. $\text{replace}(\text{vqb}(z), \text{vqb}(v), \langle \text{thing}(z) \rangle)$
 $= \text{replace}(z + u, v + t, \langle \text{thing}(z) \rangle)$
 $= \langle \text{thing}(v) \rangle$
- b. $\text{replace}(\text{vqb}(z), \text{vqb}(v), \text{replace}(y, w, \text{sqb}(z)))$
 $= \text{replace}(z + u, v + t, \text{replace}(y, w, \langle \text{said}(y, z, u) \rangle))$
 $= \langle \text{said}(w, v, t) \rangle$
- c. $\text{replace}(\text{vqb}(u), \text{vqb}(t), \langle \text{person_or_people}(u) \rangle)$
 $= \text{replace}(z + u, v + t, \langle \text{person_or_people}(u) \rangle)$
 $= \langle \text{person_or_people}(t) \rangle$
- d. $\text{replace}(\text{vqb}(u), \text{vqb}(t), \text{replace}(y, w, \text{sqb}(u)))$
 $= \text{replace}(z + u, v + t, \text{replace}(y, w, \langle \text{said}(y, z, u) \rangle))$
 $= \langle \text{said}(w, v, t) \rangle$

Finally, the *copy* function places these values into the position indicated by $\boxed{1}$, yielding the following legitimate MRS representation, which expresses adequate truth conditions.

- (86) $j = \text{John} \wedge b = \text{Bill}$
 $\wedge \text{some}(X, X = \{j, b\},$
 $\quad \text{every}(y, \text{member_of}(y, X),$
 $\quad \quad \text{some}(z + u, \text{thing}(z)$
 $\quad \quad \quad \wedge \text{person_or_people}(u)$
 $\quad \quad \quad \wedge \text{every}(w, \text{other}(w, X, y),$
 $\quad \quad \quad \quad \text{the}(v + t, \text{thing}(v)$
 $\quad \quad \quad \quad \quad \wedge \text{said}(w, v, t)$
 $\quad \quad \quad \quad \quad \wedge \text{person_or_people}(t)$
 $\quad \quad \quad \quad \quad \wedge \text{said}(w, v, t),$
 $\quad \quad \quad \quad \quad \text{identical}(z, v) \wedge \text{different}(u, t))),$
 $\quad \quad \quad \text{said}(y, z, u)))))$

6 Negative sentences

The grammar that has been presented so far fails to account for the most salient reading of the following sentence.

- (87) Anna, Bill, Chris, and Dana didn't see different films.

The following two semantic representations can be associated with this sentence by the grammar presented so far, but neither of them corresponds to its most salient reading.

- (88) $a = \text{Anna} \wedge b = \text{Bill} \wedge c = \text{Chris} \wedge d = \text{Dana}$
 $\wedge \text{some}(X, X = \{a, b, c, d\},$
 $\quad \text{every}(y, \text{member_of}(y, X),$
 $\quad \quad \text{not}(\text{some}(z, \text{and}(\text{film_or_films}(z),$
 $\quad \quad \quad \text{every}(w, \text{other}(w, X, y),$
 $\quad \quad \quad \quad \text{the}(v, \text{film_or_films}(v) \wedge \text{saw}(w, v),$
 $\quad \quad \quad \quad \quad \text{different}(z, v))))),$
 $\quad \quad \quad \text{saw}(y, z))))))$

- (89) $a = \text{Anna} \wedge b = \text{Bill} \wedge c = \text{Chris} \wedge d = \text{Dana}$
 $\wedge \text{some}(X, X = \{a, b, c, d\},$
 $\quad \text{not}(\text{every}(y, \text{member_of}(y, X),$
 $\quad \quad \text{some}(z, \text{and}(\text{film_or_films}(z),$
 $\quad \quad \quad \text{every}(w, \text{other}(w, X, y),$
 $\quad \quad \quad \quad \text{the}(v, \text{film_or_films}(v) \wedge \text{saw}(w, v),$
 $\quad \quad \quad \quad \quad \text{different}(z, v))))),$
 $\quad \quad \quad \quad \quad \text{saw}(y, z))))))$

In its most salient reading, which may well be its only possible reading, sentence (87) is false if Anna and Bill saw *Casablanca* and Chris and Dana saw *Shane*. The representation in (88) would be true in that situation, and is hence inadequate. The representation in (89), in which the negation outscopes the first *every*, expresses even weaker truth conditions, and is thus inadequate as well. Intuitively, what is wrong with (88) is the quantifier *every* in line 5; the representation as a whole would become adequate if that occurrence of *every* were replaced with *some*.

This issue is arguably related to the issue posed by the following sentence.

- (90) Tracy, Chris and Mary don't know each other.
 (from Haug and Dalrymple (2020))

Haug and Dalrymple (2020) attribute to J. Dotlačil the observation that this sentence means that none of the three people know any of the other people. Notice that this interpretation is not what is obtained by simply negating the interpretation of the corresponding positive sentence, *Tracy, Chris and Mary know each other*, which means that each of the three people knows both the other two people.

In order to deal with the issues raised by sentences like (87) and (90), I propose the following hypothesis: the way distributive interpretation is realized in negative sentences is different from the way it is realized in positive sentences. Specifically, I postulate two phonologically null lexical items that correspond to DIST1 and DIST2 but can be used only in negative sentences. The first one, which corresponds to DIST1, has syntactic and semantic properties that are roughly the same as those of the floated quantifier *any of them*, used in the following sentences.

- (91) That bunch of little girls couldn't any of them lead a kitten to a bowl of milk!
 (<https://www.jstor.org/stable/30176796>)
- (92) ... the girls hadn't any of them ever had anything except the flour sack cotton dresses she made them.
 (from *Wilma* by Jim Hammons, 2004)

The lexical entry for this lexical item is given in Fig. 11. The second lexical item that I postulate has a meaning analogous to "any of", and corresponds to DIST2. The lexical entry for this lexical item is given in Fig. 12.

Given these lexical entries, the grammar can associate sentence (87) with the semantic representation in (93) and sentence (90) with the semantic representation in (94). In both cases, the same semantic representation is produced irrespective of whether the lexical entry corresponding to DIST1 is used or the one corresponding to DIST2 is used.

- (93) $a = \text{Anna} \wedge b = \text{Bill} \wedge c = \text{Chris} \wedge d = \text{Dana}$
 $\wedge \text{some}(X, X = \{a, b, c, d\},$
 $\quad \text{not}(\text{some}(y, \text{member_of}(y, X),$
 $\quad \quad \text{some}(z, \text{and}(\text{film_or_films}(z),$

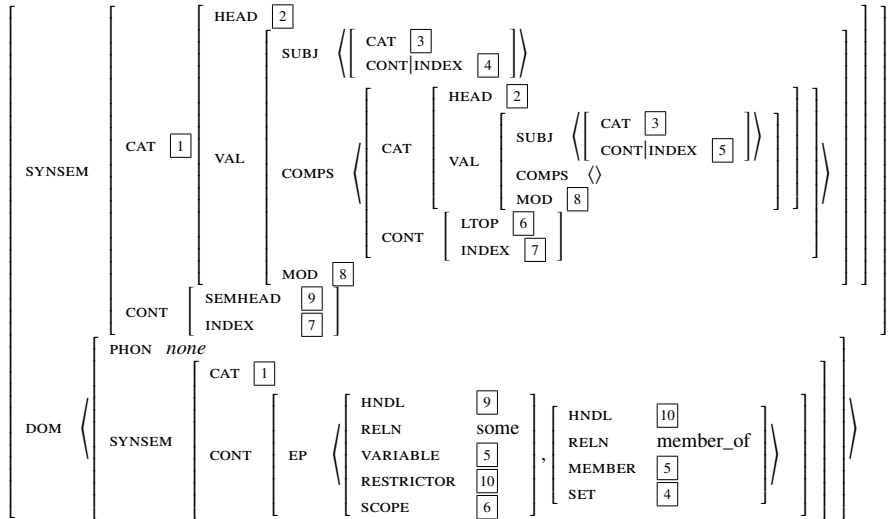

Condition: [9] is the SCOPE argument of *not*.

Figure 11: The lexical entry for the silent floated quantifier meaning *any of them*

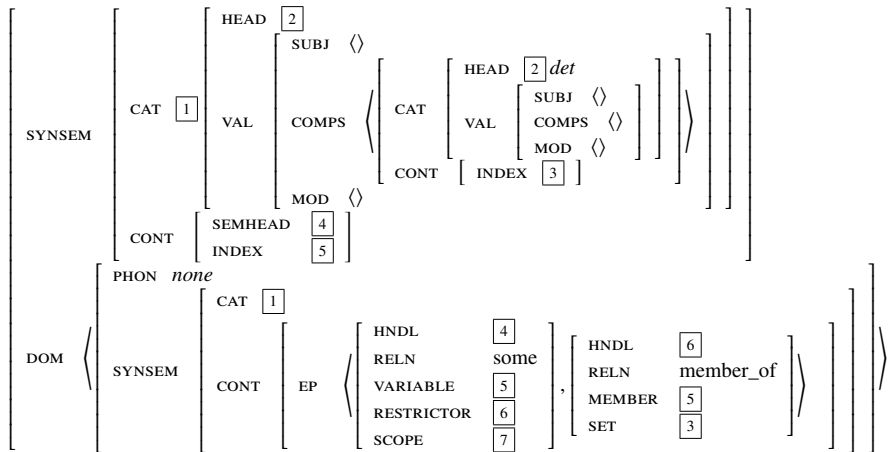

Condition: [4] is the SCOPE argument of *not*.

Figure 12: The lexical entry for the silent lexical item meaning “any of”

- $$\text{some}(w, \text{other}(w, X, y), \\ \text{the}(v, \text{film_or_films}(v) \wedge \text{saw}(w, v), \\ \text{different}(z, v))))), \\ \text{saw}(y, z))))))$$
- (94) $t = \text{Tracy} \wedge c = \text{Chris} \wedge m = \text{Mary}$
 $\wedge \text{some}(X, X = \{t, c, m\},$
 $\text{not}(\text{some}(z, \text{member_of}(z, X),$
 $\text{some}(y, \text{other}(y, X, z),$
 $\text{know}(z, y))))))$

These express adequate truth conditions because, in each of these semantic representations, the *qb* function has duplicated a quantifier *some* provided by one of the two silent lexical items that I have just postulated, rather than a quantifier *every* provided by either DIST1 or DIST2.

If it is necessary to rule out representations like (88) and (89), then some conditions will have to be added to the lexical entries for DIST1 and DIST2. At the moment it is not clear to me whether it is necessary to do so.

7 Symmetrical predicates without antecedents

Carlson (1987) and Barker (2007) claim that examples like the following indicate that the antecedent of a symmetrical predicate such as *different* can be a coordinate structure whose conjuncts are not DPs or NPs.

- (95) Different people discovered America and invented bifocals.
(96) John saw and reviewed different films.
(97) John read and reviewed the same book.

The theory that I have developed in the present article is not applicable to examples like these. As I will argue below, however, that is not a problem for the theory. It is my contention that the symmetrical predicates in these sentences do not have antecedents and that the apparent internal readings of these sentences arise in a way entirely different from the way the internal reading of a sentence like (1) arises.

It is not difficult to show that *different* does not always have what can be regarded as its antecedent. Consider an example like the following.

- (98) Different people like different books.

The second *different* can be viewed as an instance of the hidden-reciprocal *different* whose antecedent is the subject DP, but there is no expression that can be regarded as the antecedent of the first *different*.

I claim that *different* can denote a one-place predicate that is satisfied if and only if its argument denotes a group whose members are distinct from each other. This claim is in fact already widely accepted; for example, it is stated in Carlson (1987) that *different* sometimes merely means “various”. If we view the first occurrence of *different* in (98) as an instance of such a one-place predicate, then the sentence can be given a semantic representation like (99).

- (99) $\text{some}(X, \text{different}(X) \wedge \text{people}(X),$
 $\text{every}(y, \text{member_of}(y, X),$
 $\text{some}(z, \text{and}(\text{book}(z),$
 $\text{every}(w, \text{other}(w, X, y),$

$$\text{the}(v, \text{book}(v) \wedge \text{like}(w, v), \\ \text{different}(z, v))), \\ \text{like}(y, z)))))$$

Similarly, I hypothesize that *the same* can function as a one-place predicate that is satisfied if its argument is a degenerate group whose supposed members are identical to each other. An example like the following lends plausibility to the hypothesis.

(100) Clark Kent and Superman are the same person.

Given appropriate assumptions about the verb *are*, this sentence is associated with a semantic representation like the following, which expresses adequate truth conditions as long as the hypothesis in question is adopted.

(101) $c = \text{Clark Kent} \wedge s = \text{Superman}$
 $\wedge \text{some}(X, X = \{c, s\},$
 $\text{the_same}(X) \wedge \text{person}(X))$

The symmetrical predicates that are used in (95), (96), and (97) can all be such one-place predicates that do not require any antecedents, rather than more complex kinds of predicates whose meaning involves that of a reciprocal pronoun. The correct truth conditions of these sentences can be obtained if it is assumed that (95), (96), and (97) involve left-node raising of *different people* out of two clauses, right-node raising of *different films* out of two VPs, and right-node raising of *the same book* out of two VPs, respectively. In the theory of right-node raising and left-node raising defended in Yatabe and Tam (2021), a right- or left-node-raised expression may be given a composite index whose components are the indices that the expression is given before application of right- or left-node raising. As a result, sentence (95) can be associated with a semantic representation that means “for some $x + y$ such that $x + y$ are different people, x discovered America and y invented bifocals”, if *different people* is taken to have been left-node-raised. Sentence (96) can be associated with a semantic representation that means “for some $x + y$ such that $x + y$ are different films, John saw x and reviewed y ”, if *different films* is taken to have been right-node-raised. And sentence (97) can be associated with a semantic representation that means “for some $x + y$ such that $x + y$ are the same book, John read x and reviewed y ”, if *the same book* is taken to have been right-node-raised. The details of this line of analysis are presented in Yatabe and Tam (2021, Sect. 2.4.2).

While the existence of right-node raising in English is a universally acknowledged fact, the view that English also has left-node raising may not be as widely shared. The following examples, however, are all difficult to account for unless the existence of left-node raising is assumed.

(102) John drove to Chicago in the morning and Detroit in the afternoon.
 (from Dowty (1988))

(103) Many former soldiers living in England and resistance members living in France have similar memories.
 (from Milward (1994))

(104) Your family won't have any trouble getting past the border, as long as no one (either) is caught with a gun, or has left their gun license at home.
 (from Kubota and Levine (2015))

These sentences can be analyzed as involving left-node raising of *drove to*, *many former*, and *no one*, respectively.

8 Concluding remarks

In this article, I have presented and defended a theory of the internal readings of symmetrical predicates such as *different* and *the same* in which the meaning of such predicates is taken to contain the meaning of a reciprocal pronoun. The theory was shown to be able to account for the truth conditions of sentences in which the antecedent of a symmetrical predicate is a quantificational DP, sentences in which *the same* is used as part of a partitive construction, sentences containing multiple symmetrical predicates, and sentences in which a symmetrical predicate is under the scope of a negation. In addition, I have presented a novel theory of the semantics of reciprocal pronouns that is capable of assigning adequate truth conditions to sentences in which a right-node-raised reciprocal pronoun is anteceded by more than one DP simultaneously and sentences in which the antecedent of a reciprocal pronoun is a DP headed by a determiner like *most* and *no*. Both these theories are HPSG-based and unabashedly representationalist, involving constraints on the form of semantic representations and, in the case of the former, even operations that copy and modify parts of semantic representations. It is an open question whether a comparable empirical coverage can be achieved by some other type of theory as well.

References

- Barker, C.: 2007, 'Parasitic Scope', *Linguistics and Philosophy* **30**, 407–444.
- Barker, C. and C.-c. Shan: 2014, *Continuations and Natural Language*, Oxford University Press, Oxford.
- Beck, S.: 2000, 'The Semantics of *different*: Comparison Operator and Relational Adjective', *Linguistics and Philosophy* **23**, 101–139.
- Brasoveanu, A.: 2011, 'Sentence-Internal *different* as Quantifier-internal Anaphora', *Linguistics and Philosophy* **34**, 93–168.
- Carlson, G. N.: 1987, 'Same and Different: Some Consequences for Syntax and Semantics', *Linguistics and Philosophy* **10**, 531–565.
- Charnavel, I.: 2015, '*Same, different, and other* as Comparative Adjectives—A Uniform Analysis Based on French', *Lingua* **156**, 129–174.
- Chaves, R. P.: 2014, 'On the Disunity of Right-Node Raising Phenomena: Extraposition, Ellipsis, and Deletion', *Language* **90**(4), 834–886.
- Copestake, A., D. Flickinger, C. Pollard and I. A. Sag: 2005, 'Minimal Recursion Semantics: An Introduction', *Research on Language and Computation* **3**, 281–332.
- Dalrymple, M., M. Kanazawa, Y. Kim, S. Mchombo and S. Peters: 1998, 'Reciprocal Expressions and the Concept of Reciprocity', *Linguistics and Philosophy* **21**, 159–210.
- Dalrymple, M., J. Lamping, F. Pereira and V. Saraswat: 1999, 'Quantification, Anaphora, and Intensionality', in M. Dalrymple (ed.), *Semantics and Syntax in Lexical Functional Grammar*, MIT Press, Cambridge, Massachusetts, pp. 39–89.

- Dowty, D.: 1988, 'Type Raising, Functional Composition, and Non-Constituent Conjunction', in R. T. Oehrle, E. Bach and D. Wheeler (eds.), *Categorial Grammars and Natural Language Structures*, D. Reidel Publishing Company, Dordrecht, pp. 153–197.
- Fox, D. and K. Johnson: 2016, 'QR is Restrictor Sharing', in K.-m. Kim, P. Umbal, T. Block, Q. Chan, T. Cheng, K. Finney, M. Katz, S. Nickel-Thompson and L. Shorten (eds.), *Proceedings of the 33rd West Coast Conference on Formal Linguistics*, Cascadilla Proceedings Project, Somerville, MA, pp. 1–16.
- Haug, D. T. T. and M. Dalrymple: 2020, 'Reciprocity: Anaphora, Scope, and Quantification', *Semantics and Pragmatics* **13**.
- Heim, I., H. Lasnik and R. May: 1991a, 'Reciprocity and Plurality', *Linguistic Inquiry* **22**, 63–101.
- Heim, I., H. Lasnik and R. May: 1991b, 'On "Reciprocal Scope"', *Linguistic Inquiry* **22**, 173–192.
- Iatridou, S. and I. Sichel: 2011, 'Negative DPs, A-Movement, and Scope Diminishment', *Linguistic Inquiry* **42**, 595–629.
- Kamp, H. and U. Reyle: 1993, *From Discourse to Logic: Introduction to Modeltheoretic Semantics of Natural Language, Formal Logic and Discourse Representation Theory, Part 1 and Part 2*, Kluwer, Dordrecht.
- Keenan, E. L.: 1987, 'Unreducible n-ary Quantifiers in Natural Language', in P. Gärdenfors (ed.), *Generalized Quantifiers: Linguistic and Logical Approaches*, Reidel, Dordrecht, pp. 109–150.
- Kubota, Y. and R. Levine: 2015, 'Against Ellipsis: Arguments for the Direct Licensing of 'Noncanonical' Coordinations', *Linguistics and Philosophy* **38**, 521–576.
- Kubota, Y. and R. Levine: 2016, 'The Syntax-Semantics Interface of 'Respective' Predication: A Unified Analysis in Hybrid Type-Logical Categorial Grammar', *Natural Language & Linguistic Theory* **34**, 911–973.
- Kubota, Y. and R. D. Levine: 2020, *Type-Logical Syntax*, MIT Press, Cambridge, Massachusetts.
- Marsden, H. L.: 2005, *Quantifier Scope in Non-Native Japanese: A Comparative Interlanguage Study of Chinese-, English- and Korean-Speaking Learners*, Ph.D. thesis, Durham University, <http://etheses.dur.ac.uk/1272/>.
- Milward, P.: 1994, 'Non-constituent Coordination: Theory and Practice', in *Proceedings of the 15th International Conference on Computational Linguistics*, pp. 935–941.
- Pollard, C. and I. A. Sag: 1994, *Head-Driven Phrase Structure Grammar*, University of Chicago Press, Chicago.
- Pullum, G. K. and R. Huddleston: 2002, *The Cambridge Grammar of the English Language*, Cambridge University Press, Cambridge.

- Richter, F.: 2016, 'Categorematic Unreducible Polyadic Quantifiers in Lexical Resource Semantics', in D. Arnold, M. Butt, B. Crysmann, T. H. King and S. Müller (eds.), *Proceedings of the Joint 2016 Conference on Head-driven Phrase Structure Grammar and Lexical Functional Grammar*, CSLI, Stanford, pp. 599–619, <http://csli-publications.stanford.edu/HPSG/>.
- Yatabe, S.: 1988, 'Implicit Arguments of *different*', in *Linguistic Research: Working Papers in English Linguistics*, vol. 6, Tokyo University English Linguistics Association, pp. 141–163.
- Yatabe, S. and W. L. Tam: 2021, 'In Defense of an HPSG-Based Theory of Non-Constituent Coordination: A Reply to Kubota and Levine', *Linguistics and Philosophy* **44**, 1–77.
- Zuber, R.: 2017, 'Set Partitions and the Meaning of *the Same*', *Journal of Logic, Language and Information* **26**, 1–20.
- Zweig, E.: 2009, 'Number-neutral Bare Plurals and the Multiplicity Implicature', *Linguistics and Philosophy* **32**, 353–407.